

Commonwealth of Kentucky DEPARTMENT OF HIGHWAYS

PLANS OF PROPOSED PROJECT McCREARY/WHITLEY COUNTIES KY 92 FD04 118 0092 016-026 009D



INDEX OF SHEETS	
SHEET NO.	DESCRIPTION
R1	LAYOUT SHEET
R2 - R2J	TYPICAL SECTIONS-SUMMARY OF QUANTITIES
R3 - R35F	PLAN AND PROFILE SHEETS
R36 - R37	RIGHT OF WAY SUMMARY SHEETS
R38 - R41	RIGHT OF WAY STRIP MAP SHEETS
R42 - R43	COORDINATE CONTROL SHEETS
R44	RIGHT OF WAY MONUMENTATION SHEET
S	STRUCTURE PLANS
T	TRAFFIC PLANS
U	UTILITY RELOCATION PLANS
X	CROSS SECTION SHEETS

SHEETS NOT INCLUDED IN TOTAL SHEETS
R2A, R2B, R2C, R2D, R2E, R2F, R25A, R35A, R35B, R35C, R35D, R35E, R35F

STANDARD DRAWINGS	
NUMBER	
RBB-001-07	RDI-020-08
RBC-001-10	RDI-021
RBC-002-02	RDI-025-04
RBC-003-07	RDI-026
RBE-060-13	RDP-001-05
RBI-001-10	RDP-005-04
RBI-002-06	RDP-006-03
RBI-004-04	RDP-010-08
RBM-115-09	RDX-160-05
RBR-010-05	RDX-210-02
RBR-015-04	RDX-220-04
RBR-016-04	RDX-225
RBR-020-05	RDX-230
RBR-030-04	RGS-001-06
RBR-031	RGX-001-05
RBR-035-10	RGX-010-03
RDB-105-05	RGX-015-02
RDB-106-04	RGX-100-05
RDB-150-01	RGX-105-07
RDB-160-01	RGX-200
RDB-280-05	RPM-100-09
RDB-281-02	RPM-110-06
RDB-282-03	TTC-100-03
RDB-283-03	TTC-155-01
RDD-040-04	TTD-110-01
RDH-020-03	TTD-120-01
RDH-110-02	TTD-125-01
RDH-120-02	
RDH-210-03	
RDH-214-03	
RDH-310-04	
RDH-330-04	
RDI-001-09	
RDI-002-04	
RDI-003-04	

BEGIN RW PROJECT
STA. 132+27.97

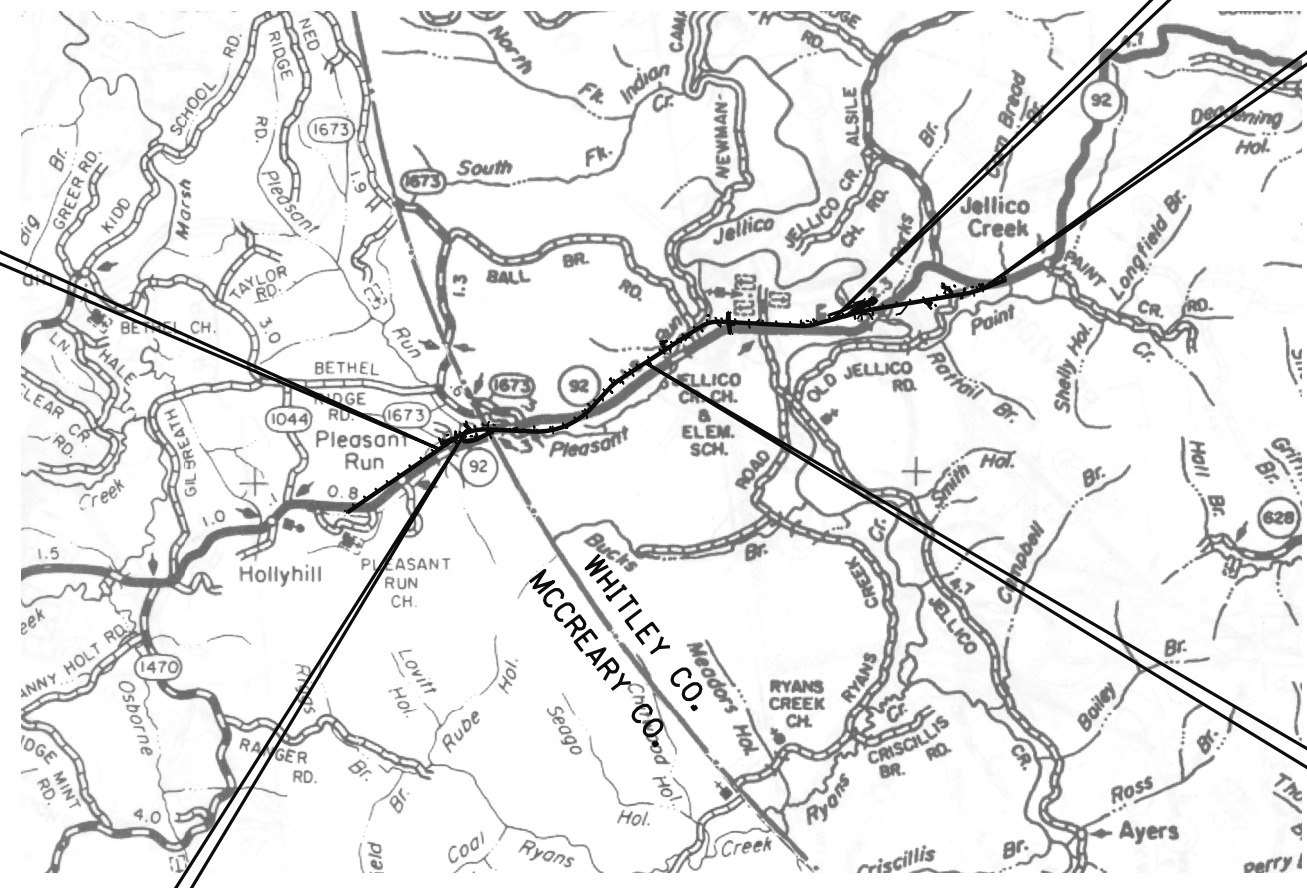

END RW PROJECT
STA. 347+00.00

THE CONTROL OF ACCESS ON THIS
PROJECT SHALL BE BY PERMIT

THIS PROJECT IS OFF THE NH SYSTEM

BRIDGE SITE 2
STA. 217+92 @ 45° SKEW RT.
3 SPAN PCI BEAM - TYPE II
(52 - 60 - 52)

BRIDGE SITE 1
STA. 143+23 @ 30° SKEW LT.
3 SPAN PCI BEAM - TYPE III
(65 - 80 - 65)

LAYOUT MAP

RIGHT OF WAY PLANS

DESIGN CRITERIA	
CLASS OF HIGHWAY	RURAL ARTERIAL
TYPE OF TERRAIN	MOUNTAINOUS
DESIGN SPEED	55 M.P.H.
REQUIRED NPSD	495'
REQUIRED PSD	1985'
LEVEL OF SERVICE	C
ADT PRESENT (2000)	1700
ADT FUTURE (2020)	2520
DHV 280 (2020)	
D %	55
T %	19
GEOGRAPHIC COORDINATES	
LATITUDE	36 DEGREES 40 MINUTES 12 SECONDS NORTH
LONGITUDE	84 DEGREES 18 MINUTES 31 SECONDS WEST
DESIGNED	
LENGTH	20,361.03 LIN. FT. 3.856 MILES
ADDED	FOR EQUALITIES N/A LIN. FT.
DEDUCTED	NOT INCLUDED
RAILROAD CROSSINGS NO.	N/A LIN. FT.
BRIDGES	III LIN. FT.
STA. 143+23 - 210', STA. 217+92 - 165', STA. 209+90 - 736'	
% RESTRICTED SD	0 (NPSD)
LEVEL OF SERVICE	B
MAX. DISTANCE W/O PASSING	6950'

LENGTH	ADDED	DEDUCTED	FOR EQUALITIES	NOT INCLUDED	RAILROAD CROSSINGS NO.	BRIDGES
_____ LIN. FT.	_____ LIN. FT.	_____ LIN. FT.	_____ LIN. FT.	_____ LIN. FT.	_____ LIN. FT.	_____ LIN. FT.
_____ MILES	_____ MILES	_____ MILES	_____ MILES	_____ MILES	_____ MILES	_____ MILES

**Commonwealth of Kentucky
DEPARTMENT OF HIGHWAYS
COUNTY OF
WHITLEY**

ITEM NO. 11-184.00

PROJECT NUMBER: FD04 118 0092 016-026

LETTING DATE: _____

RECOMMENDED BY: _____ PROJECT MANAGER DATE: _____

PLAN APPROVED BY: _____ STATE HIGHWAY ENGINEER DATE: _____

FILE NAME: G:\ENGR\HD185.0\PHASE II\CAD\PLANS\ROW\LAYOUT-RW.DGN
 USER: HOYSON
 DATE PLOTTED: June 20, 2013
 E-SHEET NAME:
 MicroStation v8.11.7.180

TYPICAL SECTIONS

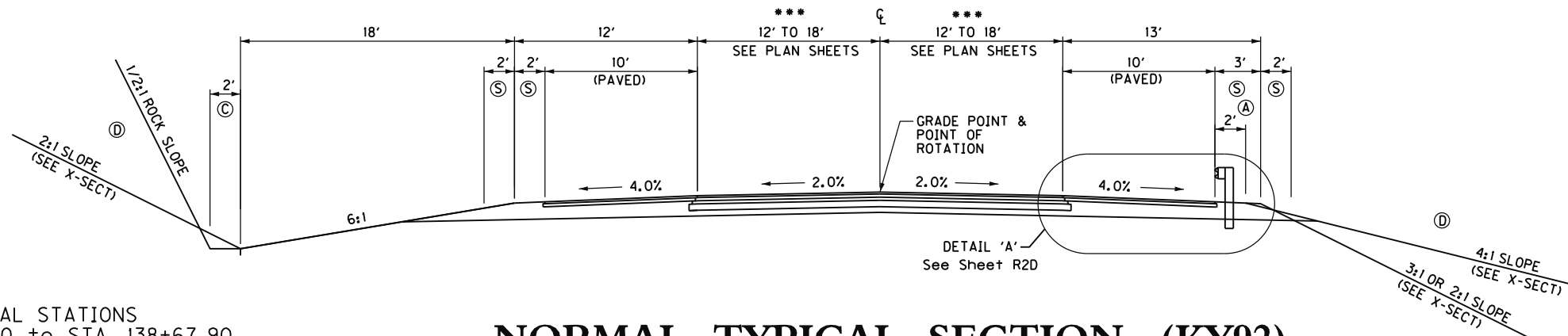

*** LT TURN LANE PAVEMENT TRANSITIONS
 STA. 145+94.30 TO STA. 149+54.30 (36' - 24')
 STA. 242+94.60 TO STA. 246+54.60 (24' - 36')
 STA. 258+53.75 TO STA. 262+13.75 (36' - 24')

NORMAL TYPICAL STATIONS
 STA. 135+00.00 to STA. 138+67.90
 STA. 151+55.32 to STA. 168+80.81
 STA. 192+32.14 to STA. 201+33.78
 STA. 207+12.08 to STA. 241+71.40
 STA. 249+64.10 to STA. 278+95.10
 STA. 284+18.57 to STA. 298+93.77
 STA. 305+78.74 to STA. 308+50.00

NORMAL TYPICAL SECTION (KY92)

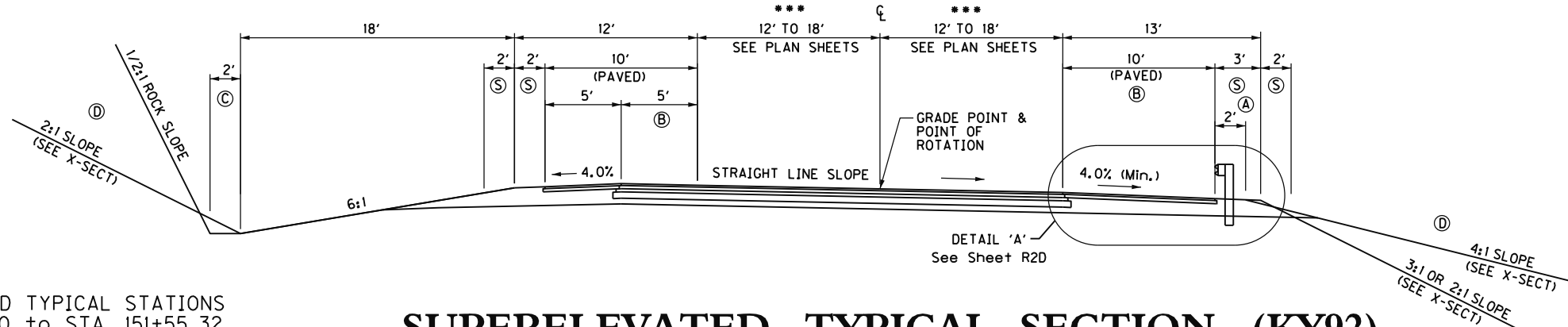

- (A) SHOULDER SHALL BE WIDENED THREE FEET WHERE GUARDRAIL IS REQUIRED
 - (B) SLOPE AT SAME RATE AS SUPERELEVATION EXCEPT NOT FLATTER THAN SLOPE INDICATED
 - (C) INCREASE DITCH WIDTH LT. & RT. TO 4' FROM STA. 304+00 to STA. 330+00
 - (D) SEE CROSS SECTIONS FOR SLOPES OUTSIDE THE LIMITS OF THE SHOULDERS
 - (S) ASPHALT SEAL COAT REQUIRED FROM THE EDGE OF PAVED SHOULDER TO A POINT TWO FEET DOWN THE CUT OR FILL SLOPE
- SEE CROSS SECTIONS FOR SLOPES OUTSIDE THE LIMITS OF THE SHOULDERS

SUPERELEVATED TYPICAL STATIONS
 STA. 138+67.90 to STA. 151+55.32
 STA. 168+80.81 to STA. 192+32.14
 STA. 201+33.78 to STA. 207+12.08
 STA. 241+71.40 to STA. 249+64.10
 STA. 278+95.10 to STA. 284+18.57
 STA. 298+93.77 to STA. 305+78.74

SUPERELEVATED TYPICAL SECTION (KY92)

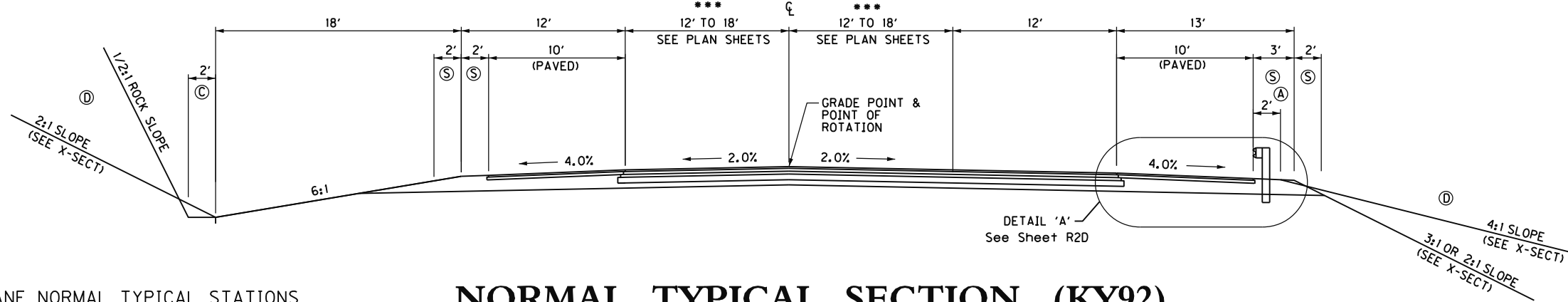

RT. TURN LANE NORMAL TYPICAL STATIONS
 LT. STA. 227+36.45 to STA. 228+85.00
 RT. STA. 250+40.00 to STA. 252+02.02
 LT. STA. 253+15.98 to STA. 249+60.00
 RT. STA. 324+90.00 to STA. 326+41.83
 LT. STA. 335+80.00 to STA. 337+30.00

**NORMAL TYPICAL SECTION (KY92)
 W/ RIGHT TURN LANE**

**RIGHT OF WAY
 PLANS**

TYPICALS

FILE NAME: G:\ENGR\HDIB5.0\PHASE II\CAD\PLANS\ROW\TYPICAL - RW.DGN
 USER: sdcgcty
 DATE PLOTTED: June 20, 2013
 E-SHEET NAME:
 MicroStation v8.11.7.180

TYPICAL SECTIONS

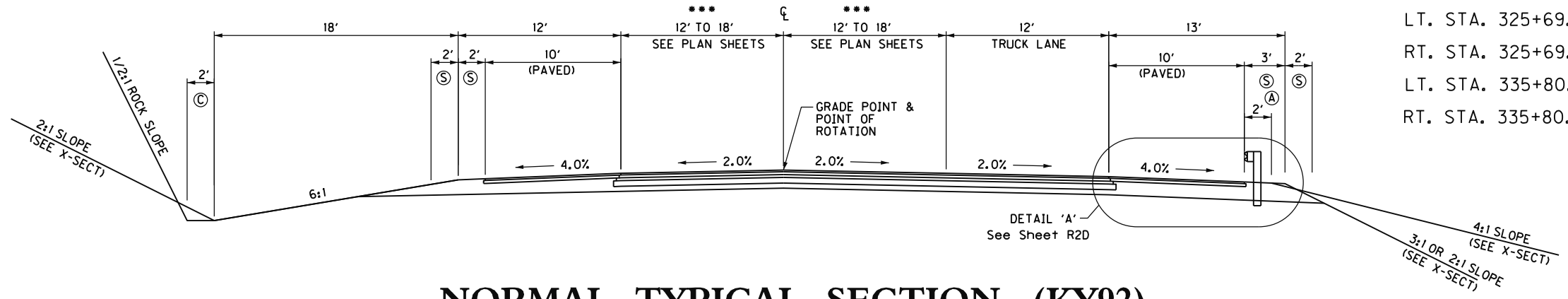

*** PAVEMENT TRANSITIONS

RT. STA. 305+50.00 TO RT. STA. 308+50.00 (12' - 24')

LT. STA. 325+69.00 TO LT. STA. 329+29.00 (12' - 18')

RT. STA. 325+69.00 TO RT. STA. 329+29.00 (24' - 30')

LT. STA. 335+80.00 TO LT. STA. 339+40.00 (18' - 12')

RT. STA. 335+80.00 TO RT. STA. 339+40.00 (30' - 24')

NORMAL TYPICAL SECTION (KY92) (TRUCK LANE)

STATION 308+50.00 TO STATION 340+26.15

- (A) SHOULDER SHALL BE WIDENED THREE FEET WHERE GUARDRAIL IS REQUIRED
- (B) SLOPE AT SAME RATE AS SUPERELEVATION EXCEPT NOT FLATTER THAN SLOPE INDICATED
- (C) INCREASE DITCH WIDTH LT. & RT. TO 4' FROM STA. 304+00 TO STA. 330+00
- (S) ASPHALT SEAL COAT REQUIRED FROM THE EDGE OF PAVED SHOULDER TO A POINT TWO FEET DOWN THE CUT OR FILL SLOPE

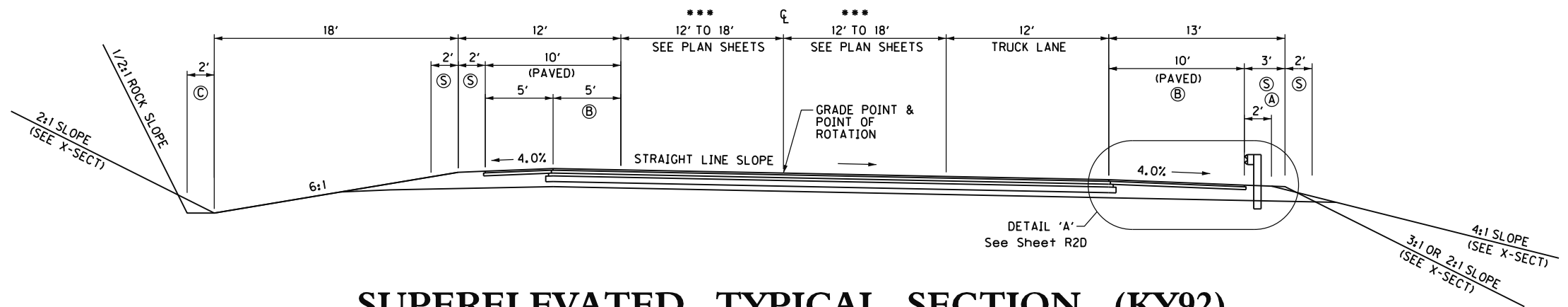

SUPERELEVATED TYPICAL SECTION (KY92) (TRUCK LANE)

STATION 340+26.15 TO STATION 346+21.98

**RIGHT OF WAY
PLANS**

TYPICALS

FILE NAME: G:\ENGR\HDIB5.0\PHASE II\CAD\PLANS\ROW\TYPICAL - RW.DGN
 USER: sdcgcty
 DATE PLOTTED: June 20, 2013
 E-SHEET NAME:
 MicroStation v8.11.7.180

TYPICAL SECTIONS

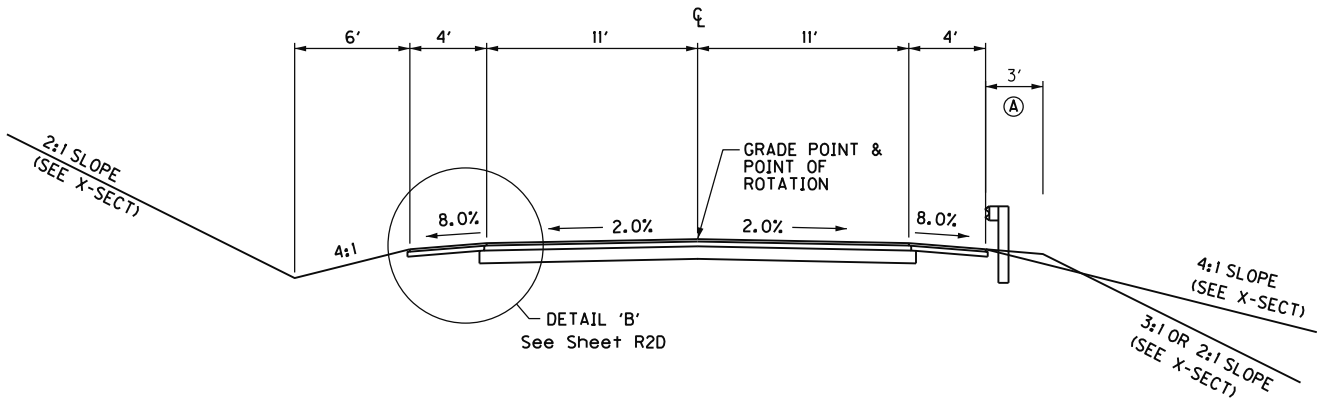

NORMAL TYPICAL SECTION

JELlico CREEK CHURCH RD. (LT. & RT. ML STA. 252+62.72)
 KY92 CONNECTOR (LT. ML STA. 335+20.00)

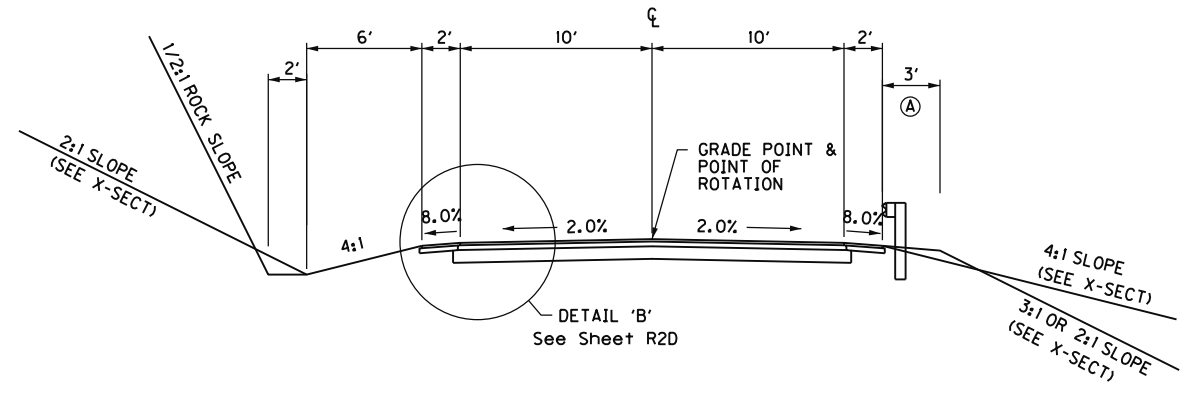

NORMAL TYPICAL SECTION

KY1673 (LT. ML STA. 145+44.95)

Ⓐ SHOULDER SHALL BE WIDENED THREE FEET WHERE GUARDRAIL IS REQUIRED

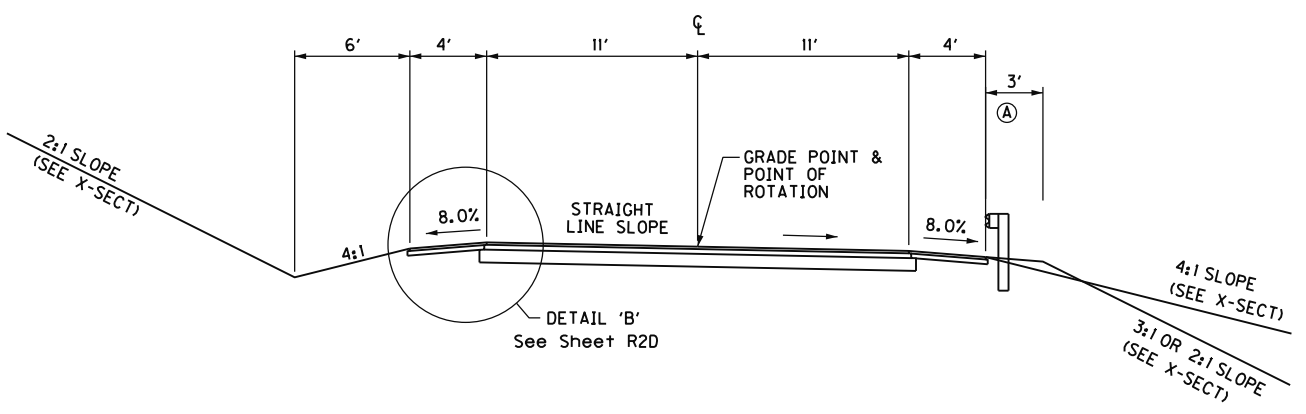

SUPERELEVATED TYPICAL SECTION

JELlico CREEK CHURCH RD. (LT. & RT. ML STA. 252+62.72)
 KY92 CONNECTOR (LT. ML STA. 335+20.00)

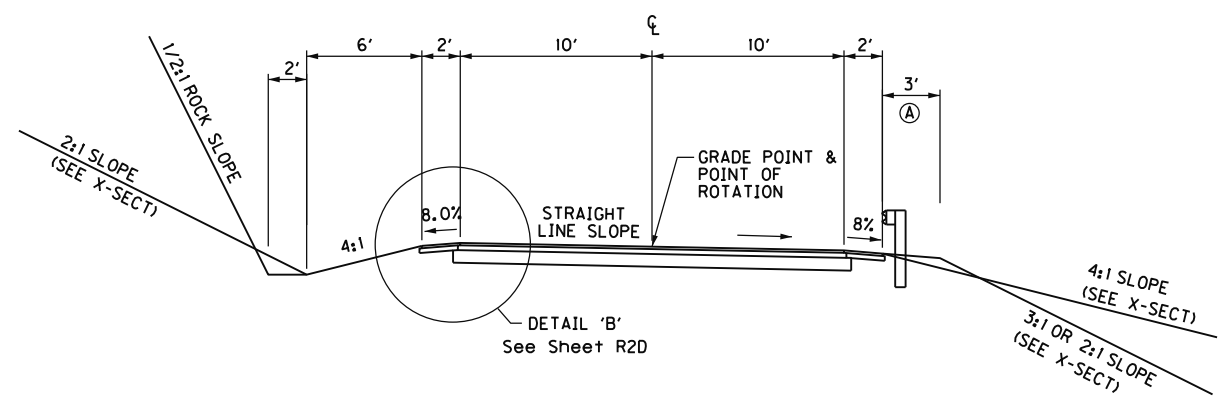

SUPERELEVATED TYPICAL SECTION

KY1673 (LT. ML STA. 145+44.95)

**RIGHT OF WAY
PLANS**

TYPICALS

FILE NAME: G:\ENGR\HDIB5.0\PHASE I\ACAD\PLANS\ROW\TYPICAL - RW.DGN
 USER: sdcgcty
 DATE PLOTTED: June 20, 2013
 E-SHEET NAME:
 MicroStation v8.11.7.180

TYPICAL SECTIONS

Note - Radius for entrances are 25 ft. unless otherwise shown.

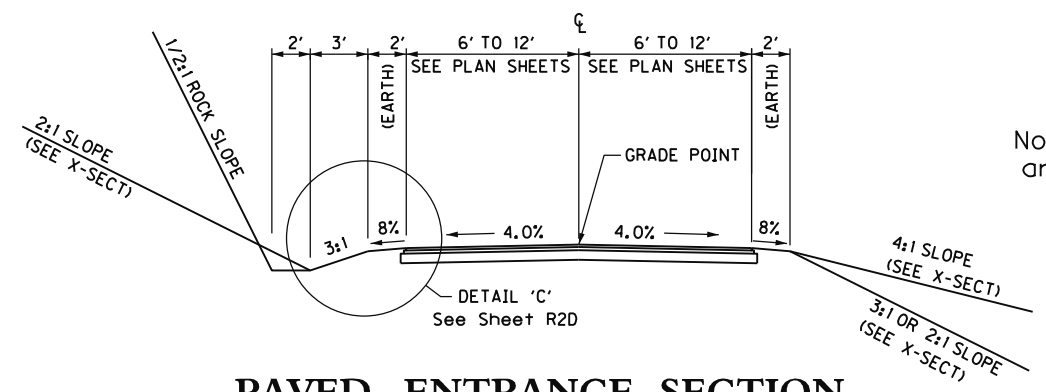

PAVED ENTRANCE SECTION

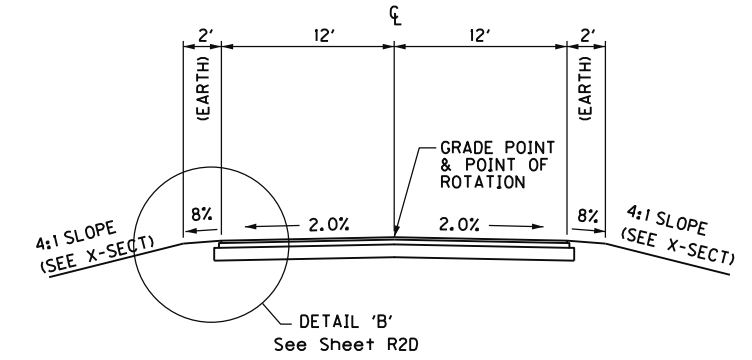

NORMAL TYPICAL SECTION

TEMPORARY KY92 CONNECTOR (LT. ML STA. 338+00.00)
(SEE MAINTENANCE OF TRAFFIC PLANS)

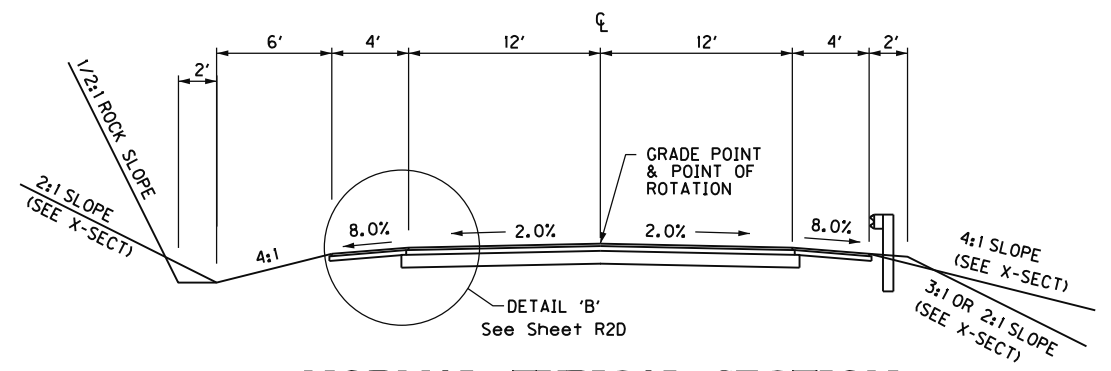

NORMAL TYPICAL SECTION

DIVERSION #1
DIVERSION #2
FRONTAGE ROAD (FRONTAGE RD CONN. STA. 48+23.91)
FRONTAGE ROAD CONNECTOR - STA. 47+88 to 50+00

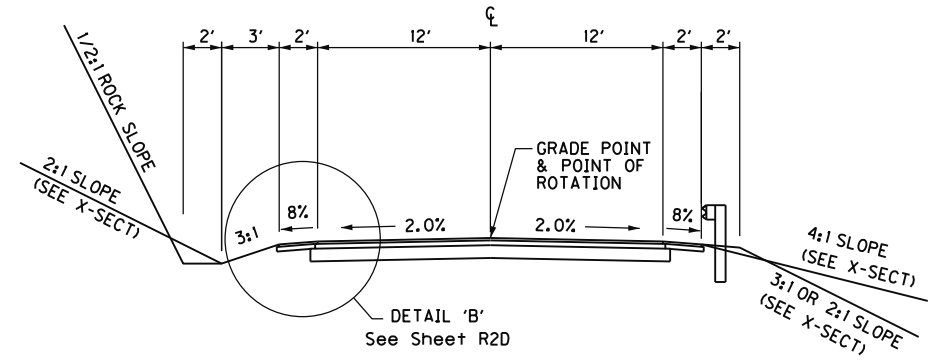

NORMAL TYPICAL SECTION

FRONTAGE ROAD CONNECTOR - STA. 46+64 to 47+88

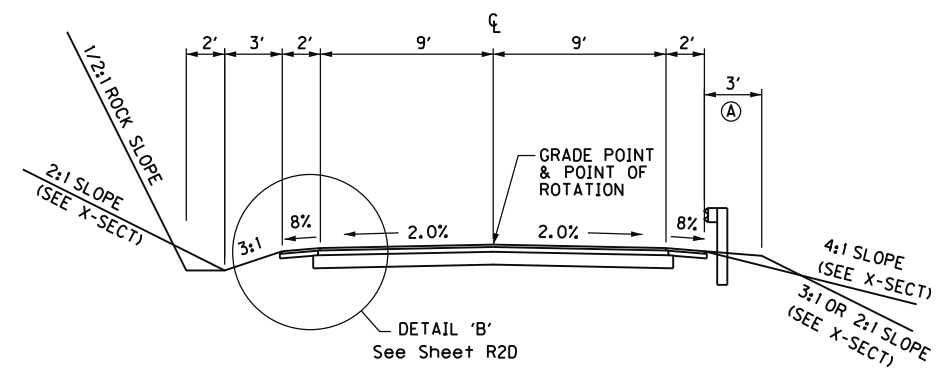

NORMAL TYPICAL SECTION

CAMPBELL RD. (LT. STA. 226+80.00)
OLD JELlico CREEK RD. (RT. ML STA. 327+00.00)

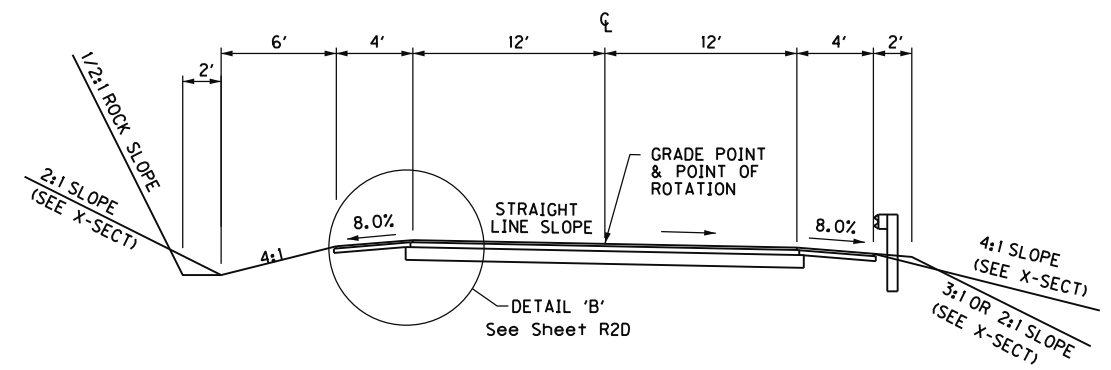

SUPERELEVATED TYPICAL SECTION

DIVERSION #1
DIVERSION #2
FRONTAGE ROAD (FRONTAGE RD CONN. STA. 48+23.91)
FRONTAGE ROAD CONNECTOR - STA. 47+88 to 50+00

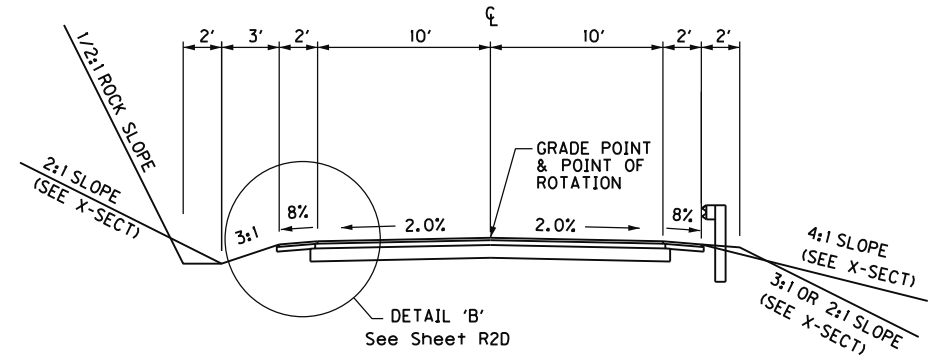

NORMAL TYPICAL SECTION

DIVERSION #4

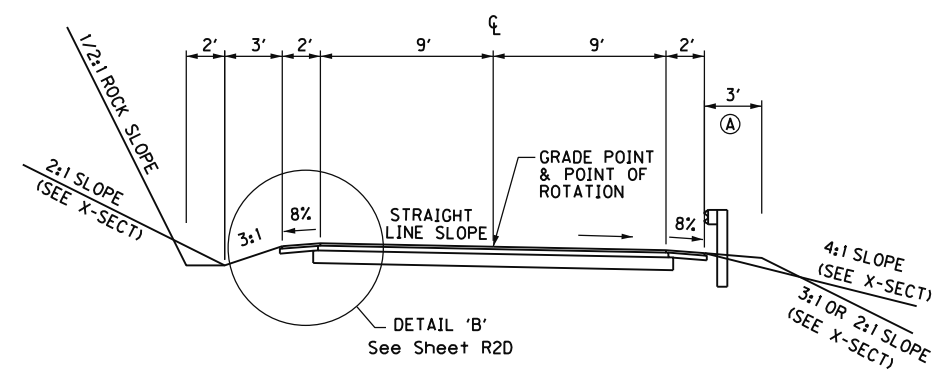

SUPERELEVATED TYPICAL SECTION

CAMPBELL RD. (LT. ML STA. 226+80.00)
OLD JELlico CREEK RD. (RT. ML STA. 327+00.00)

**RIGHT OF WAY
PLANS**

(A) SHOULDERS SHALL BE WIDENED THREE FEET WHERE GUARDRAIL IS TO BE INSTALLED

TYPICALS

FILE NAME: G:\ENGR\HDIB5.0\PHASE II\CAD\PLANS\ROW\TYPICAL - RW.DGN
 USER: sdcuerty DATE PLOTTED: June 20, 2013
 E-SHEET NAME: MicroStation v8.11.7.180

TYPICAL SECTIONS

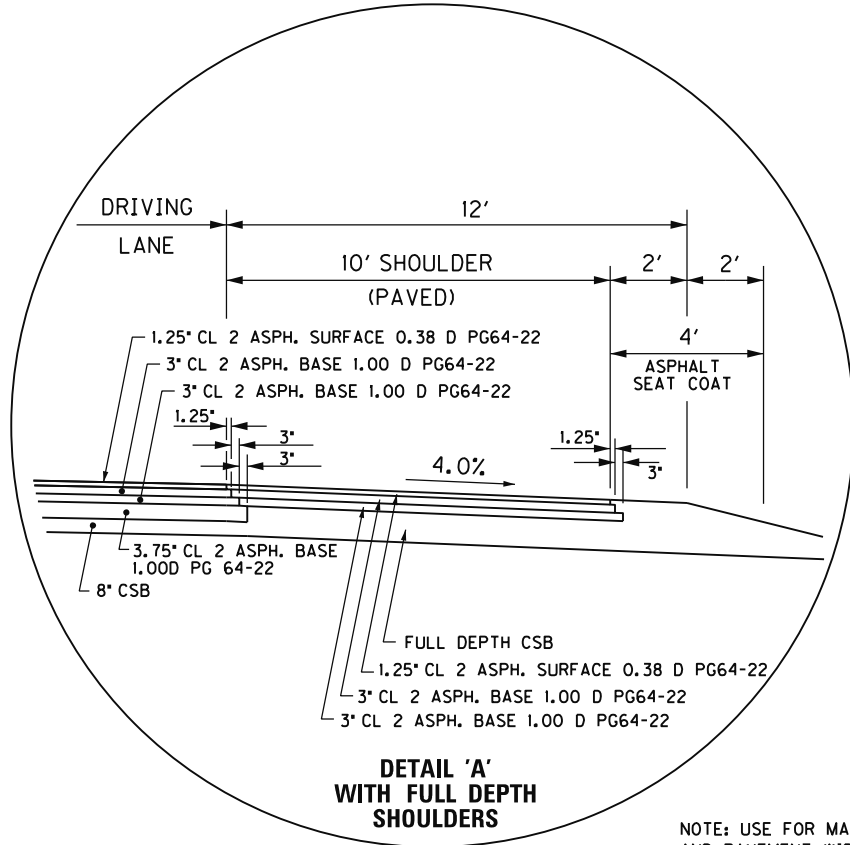
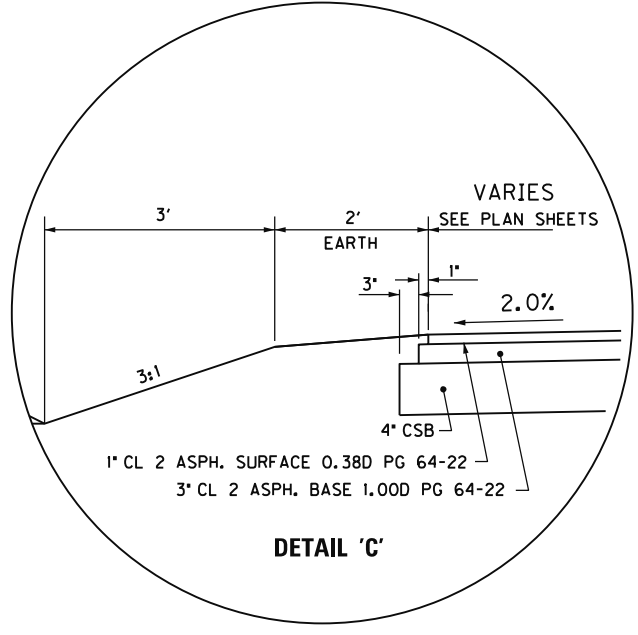
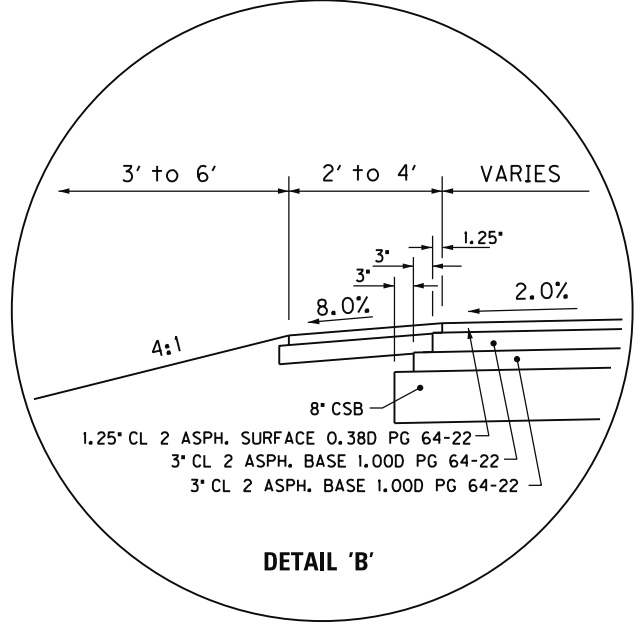
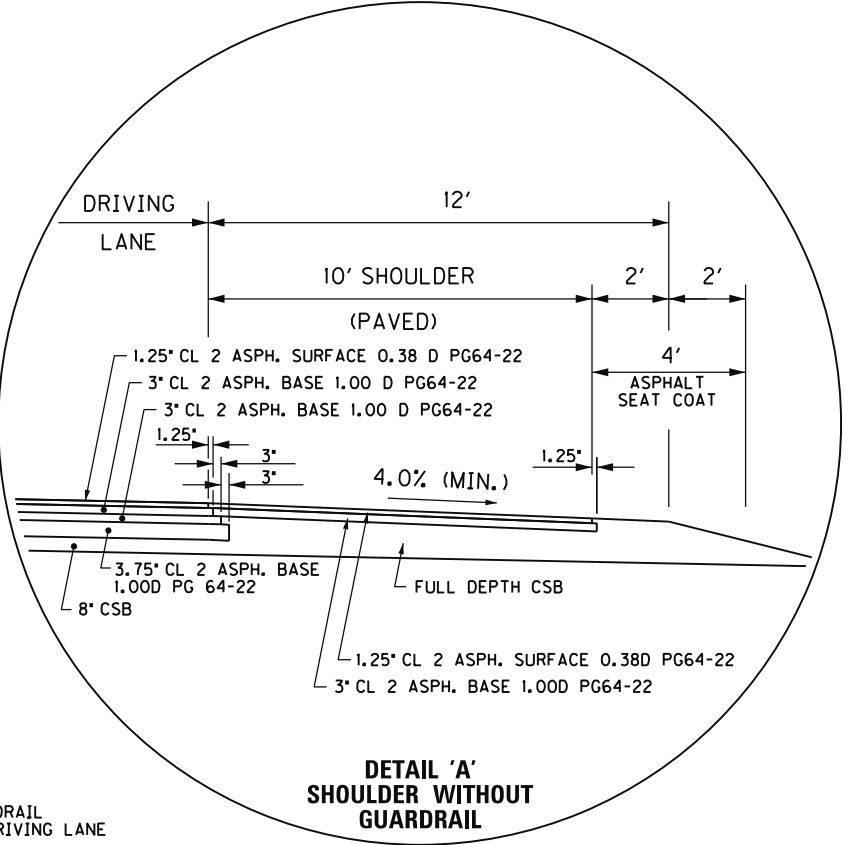
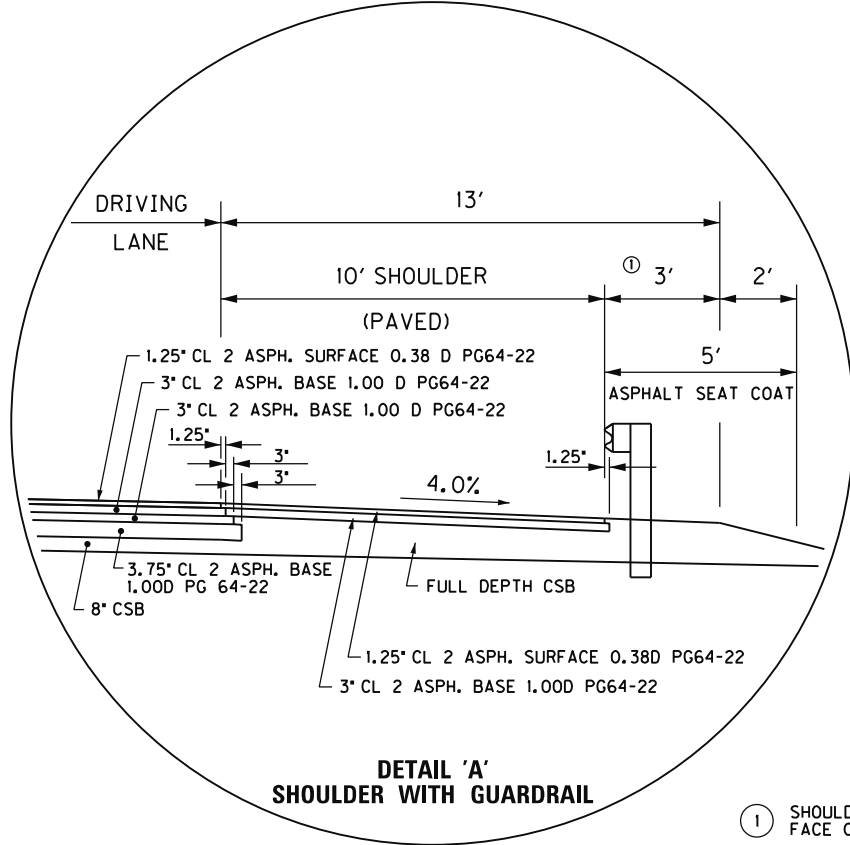

NOTE: USE FOR MAINTENANCE OF TRAFFIC AND PAVEMENT WIDENING (STA. 146+54.45 - STA. 238+00.00)

KY92 MAINLINE SURFACING SCHEDULE

Traffic Lanes		
3	CSB	8" DEPTH
212	CLASS II ASPH. BASE 1.00 D PG64-22	3.75" DEPTH
212	CLASS II ASPH. BASE 1.00 D PG64-22	6" DEPTH (3"+3")
301	CLASS II ASPH. SURF. 0.38 D PG64-22	1.25" DEPTH

Shoulders		
3	CSB	14.75" DEPTH
212	CLASS II ASPH. BASE 1.00 D PG64-22	3" DEPTH
301	CLASS II ASPH. SURF. 0.38 D PG64-22	1.25" DEPTH

ASPHALT SEAL REQUIRED FROM OUTSIDE EDGE OF PAVED SHOULDER TO A POINT 2' DOWN THE DITCH OR FILL SLOPE. TWO APPLICATIONS OF THE FOLLOWING:

100	ASPHALT SEAL AGGREGATE	20 LB/SY (SIZE NO. 8 OR 9M)
103	ASPHALT SEAL COAT	2.4 LB/SY

PLAN NOTE NO. 444,447

ALL APPROACHES SURFACING SCHEDULE

Traffic Lanes		
3	CSB	8" DEPTH
212	CLASS II ASPH. BASE 1.00 D PG64-22	6" DEPTH (3"+3")
301	CLASS II ASPH. SURF. 0.38 D PG64-22	1.25" DEPTH

Shoulders		
3	CSB	8" DEPTH
212	CLASS II ASPH. BASE 1.00 D PG64-22	3" DEPTH
301	CLASS II ASPH. SURF. 0.38 D PG64-22	1.25" DEPTH

ASPHALT ENTRANCES		
3	CSB	4" DEPTH
212	CLASS II ASPH. BASE 1.00 D PG64-22	3" DEPTH
301	CLASS II ASPH. SURF. 0.38 D PG64-22	1" DEPTH

**RIGHT OF WAY
PLANS**

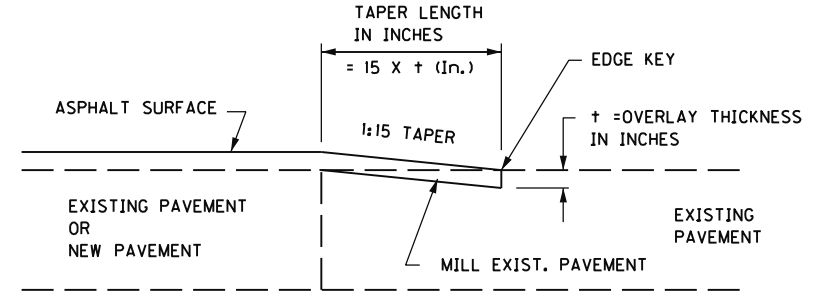

TYPICALS

FILE NAME: G:\ENGR\HDB5.0\PHASE II\CAD\PLANS\ROW\TYPICAL - RW.DGN
 USER: sdcutty
 DATE PLOTTED: June 20, 2013
 E-SHEET NAME:
 MicroStation v8.11.7.180

TYPICAL SECTIONS

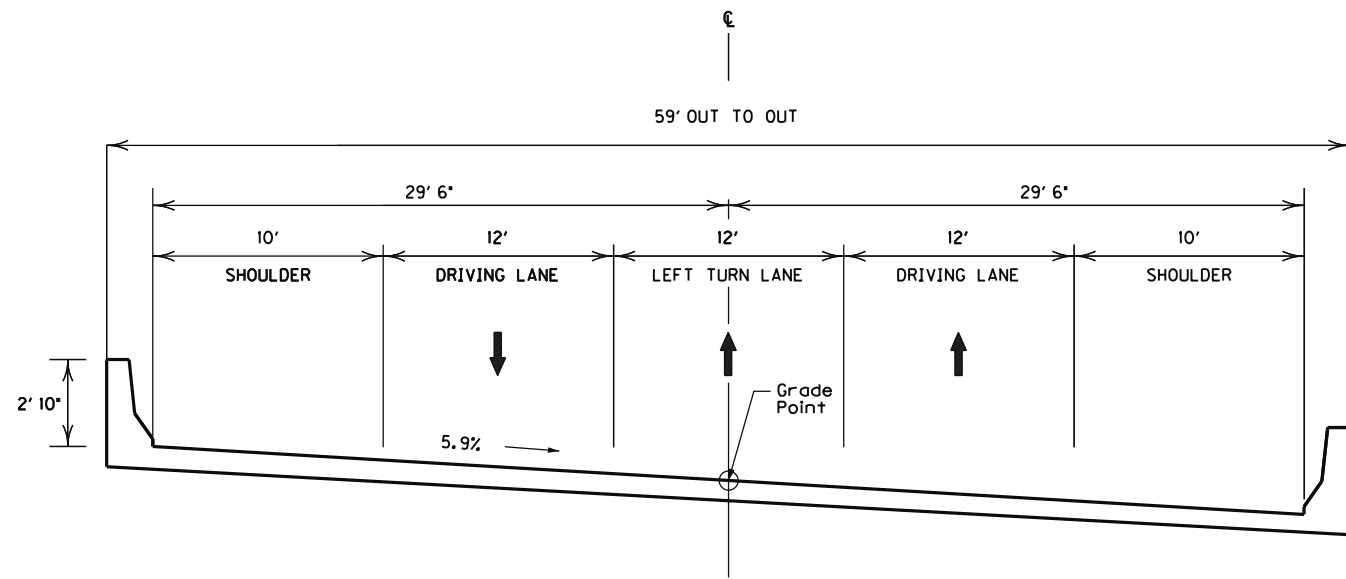

**TYPICAL BRIDGE SECTION
KY. 92 OVER PLEASANT RUN
STA. 143 + 23**

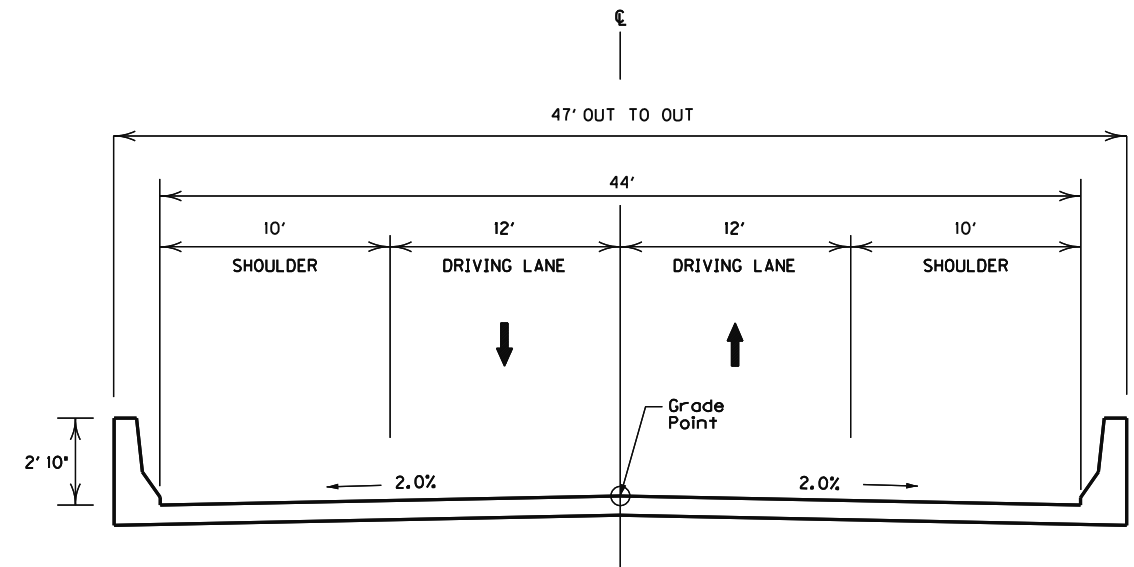

**TYPICAL BRIDGE SECTION
KY. 92 OVER JELICO CREEK
STA. 290 + 90**

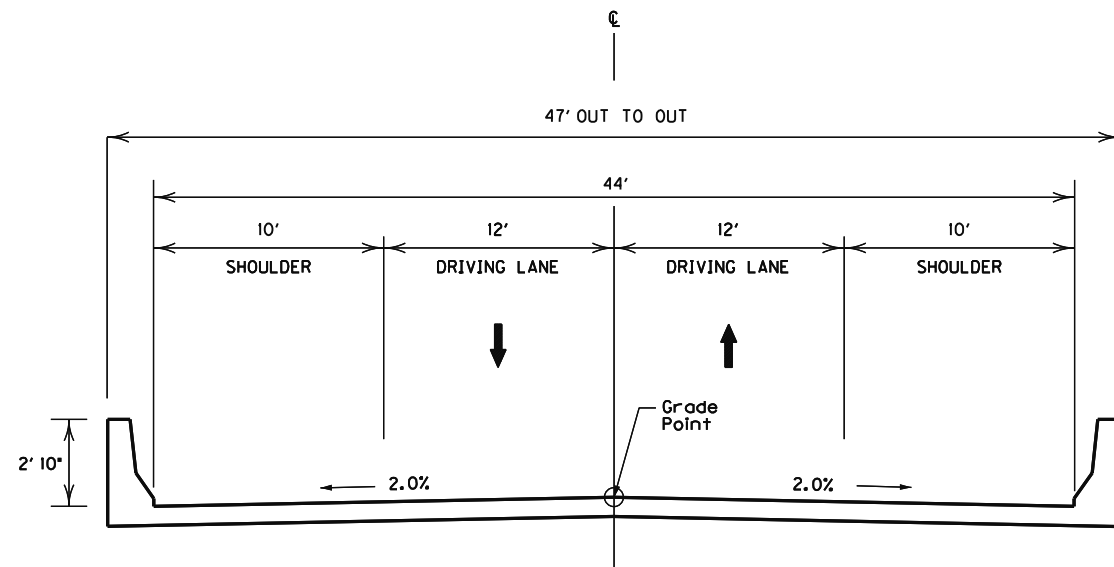

**TYPICAL BRIDGE SECTION
KY. 92 OVER PLEASANT RUN
STA. 217 + 92**

**RIGHT OF WAY
PLANS**

**MAINLINE
BRIDGE TYPICAL SECTIONS**

NOT TO SCALE

MicroStation v8.11.7.180 E-SHEET NAME: R00200CTS USER: sdcucty DATE PLOTTED: June 20, 2013 FILE NAME: G:\ENGR\HD185.01\PHASE 11\CAD\PLANS\ROW\TYPICAL - RW.DGN

COUNTY OF	ITEM NO.	SHEET NO.
WHITLEY	11-184.00	R3

KY 92 DIVERSION #1
 P.I. 137+19.42
 $\Delta = 3^{\circ}44'17''$ LT
 T = 326.32'
 L = 652.41'
 R = 10000.00'
 E = 5.32'
 e = NC
 Runoff = See Sections
 Runout = See Sections
 DESIGN SPEED 45 MPH

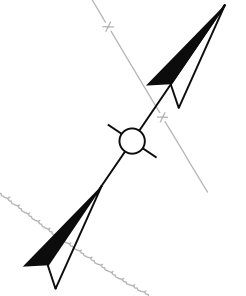

CONVENTIONAL SIGNS

SURVEY LINE
GRADE LINE
GROUND LINE
 COUNTY LINE
 CORPORATE LIMITS
 EXIST. PROPERTY LINE
 EXIST. RIGHT OF WAY & PROPERTY LINE
PROPOSED RIGHT OF WAY
RIGHT OF WAY MONUMENT

BENCH MARK
 EXISTING R/W MARKER
RIGHT OF WAY MONUMENT
 EXISTING/PROPOSED

UTILITY TEST HOLE
 EXISTING ROAD
 RAILROAD
FENCE (CONTROLLED ACCESS)
 FENCE (EXCEPT STONE AND HEDGE)
 TREE LINE
 TREES
PIPE CULVERT
CULVERT
BRIDGE
 BUILDINGS
GUARDRAIL

LIGHTING POLE
POWER POLE
 JOINT POWER & TELEPHONE POLE
 TELEPHONE & TELEGRAPH POLE
 ANCHOR, POWER OR TELEPHONE
 STUB POWER
 STUB TELEPHONE

EXISTING **PROPOSED**

WATER MAIN WM
GAS MAIN GM
TELEPHONE DUCT T
ELECTRIC DUCT E
DIRECT BURIAL TV CABLE TV
SANITARY SEWER (WITH MANHOLE) SAN
STORM SEWER (WITH MANHOLE) STORM
DIRECT BURIAL ELECTRIC CABLE E
DIRECT BURIAL TELEPHONE CABLE T
OVERHEAD WIRE
TRAFFIC LIGHTS

ELECTRIC MANHOLE (EME)
TELEPHONE MANHOLE (TME)

STONE FENCE
HEDGE FENCE

SWAMP OR MARSH
SPRINGS
SINKHOLE
QUARRY SITE

BLUE LINE STREAM
INTERMITTENT STREAM OR DITCH
LAKES OR PONDS
REGULATED FLOODWAY

NORTH POINT

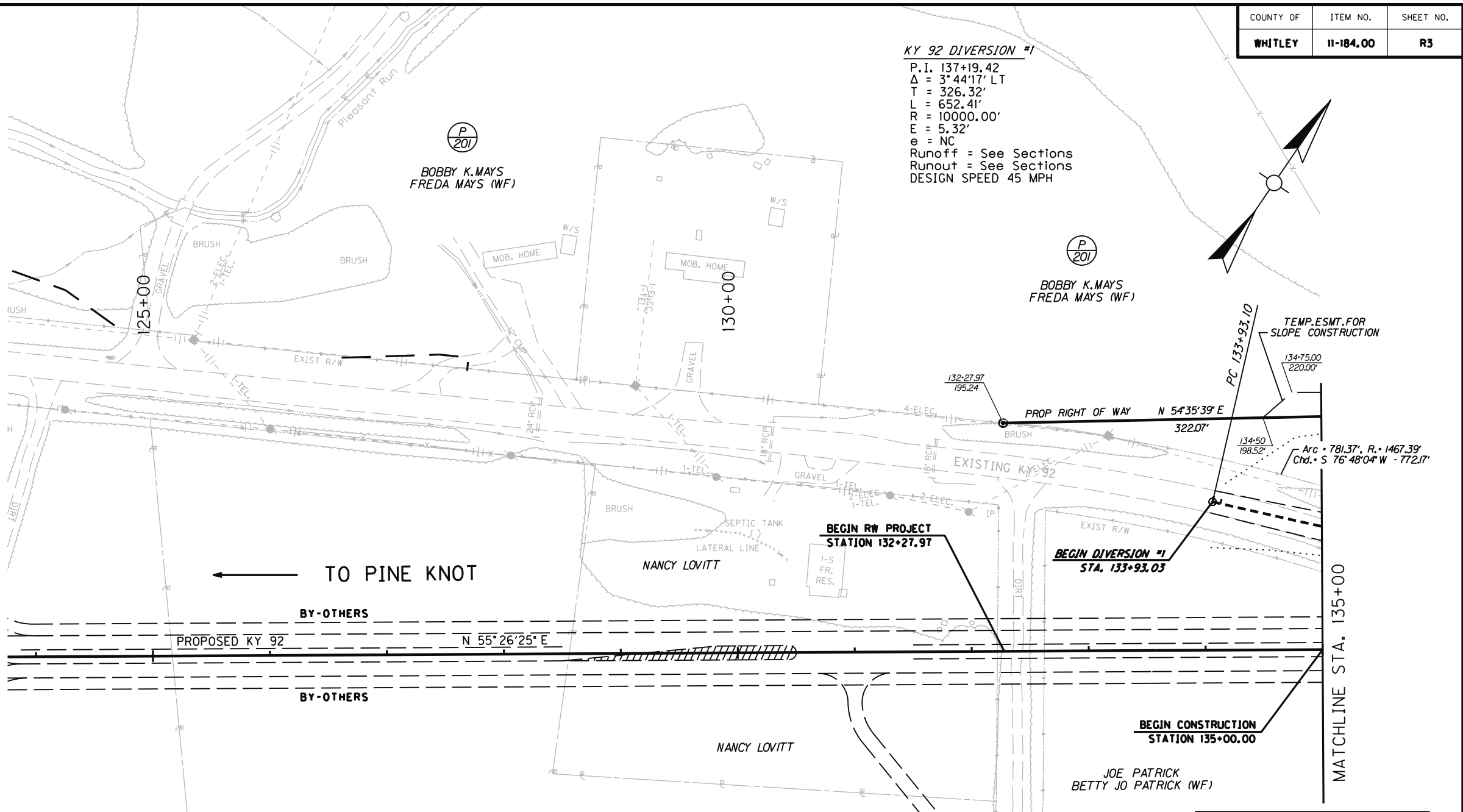

UTILITY OWNERS

WATER:
 WHITLEY COUNTY WATER DISTRICT
 19 US HIGHWAY 25W SOUTH
 WILLIAMSBURG, KY 40769
 Attn.: ALBERT MAHAN (1-606-549-3600)
 Additional Information:
 KENVIRONS ENGINEERS INC
 452 VERSAILLES ROAD
 FRANKFORT, KY. 40601
 Attn.: KEN TAYLOR (1-502-695-4357)
 www.KTAYLOR@Kenvirons.com

ELECTRIC:
 CUMBERLAND VALLEY RURAL ELECTIC
 P.O. BOX 440 / 6219 N US 25E
 GRAY, KY. 40734
 Attn.: MAARK ABNER
 Phone: 1-606-546-9295
 www.Mark.Abner@cumberlandvalley.coop

ELECTRIC:
 EAST KENTUCKY POWER COOPERATIVE
 4475 LEXINGTON ROAD P.O. BOX 707
 WINCHESTER, KY. 40392
 Attn.: SHAUN VANCE
 Phone: 1-859-527-3137
 www.Shaun.Vance@ekpc.coop

ELECTRIC
 ENERGY ASSOCIATES INC.
 2201 MAIN STREET
 WILLIAMSBURG, KY. 40769
 Phone 1-606-549-3445
 http://www.energyassociatesinc.com

ELECTRIC
 LGE-K.U.
 820 WEST BROADWAY P.O. BOX 32020
 LOUISVILLE, KY. 40232
 Attn.: GREG GEISER
 Phone: 1-606-337-0450
 www.Greg.Geiser@lge-ku.com

WATER:
 Mc CREARY COUNTY WATER DISTRICT
 P.O. BOX 488 / 19 CRIT KING ROAD
 WHITLEY CITY, KY. 42653
 Attn. STEPHEN T. OWENS
 Phone 1-606-376-2540
 www.mccrearywater.com

TELEPHONE:
 AT & T SOUTHEAST
 29 WILLS BRANCH ROAD
 PRESTONSBURG, KY. 41653
 Attn: JACK SLAYER
 Phone 1-606-874-2715
 www.js2299@att.com

GAS:
 HERBERT WHITE GAS CO.
 P.O. BOX 640
 2000 SOUTH STEMMOND FREEWAY
 LAKE DALLAS, TX. 75065

BEFORE YOU DIG

The contractor is instructed to call 1-800-752-6007 to reach KY 811, the one-call system for information on the location of existing underground utilities. The call is to be placed a minimum of two (2) and no more than ten (10) business days prior to excavation. The contractor should be aware that owners of underground facilities are not required to be members of the KY 811 one-call Before-U-Dig (BUD) service. The contractor must coordinate excavation with the utility owners, including those whom do not subscribe to KY 811. It may be necessary for the contractor to contact the County Court Clerk to determine what utility companies have facilities in the area.

RIGHT OF WAY PLANS

SCALE: 1"=50'

DESIGNED BY: _____
 DATE SUBMITTED: _____

Commonwealth of Kentucky
DEPARTMENT OF HIGHWAYS
 COUNTY OF
WHITLEY

PROJECT NUMBERS: **FD04 118 0092 016-026**

KY 92
BEGIN PROJECT TO STA. 135+00

FILE NAME: G:\ENGR\HD185_01\PHASE 1\ACAD\PLANS\ROW\12200PL.DGN
 USER: sdcufcy
 DATE PLOTTED: June 20, 2013
 E-SHEET NAME:
 MicroStation v8.11.7.180

MicroStation v8.11.7.180 E-SHEET NAME: DATE PLOTTED: June 20, 2013 USER: sdcgcty FILE NAME: G:\ENGR\H0185.01\PHASE II\CAD\PLANS\ROW\12200PR.DGN

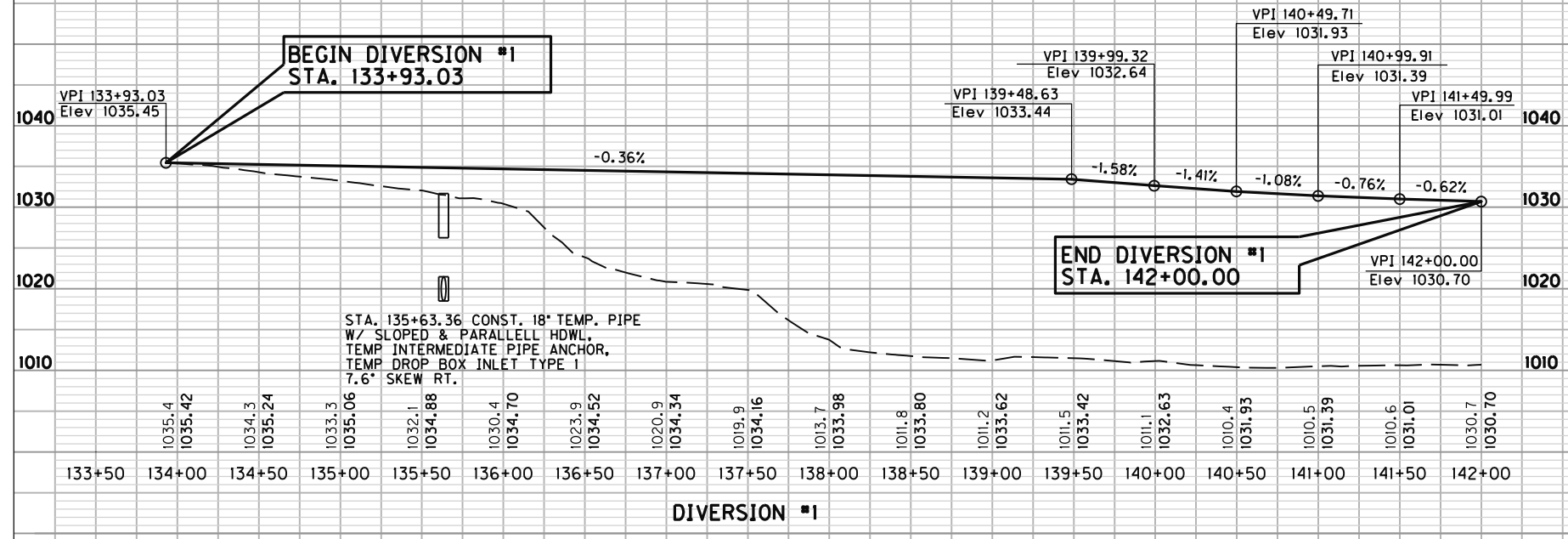

BM#1
 3/4" ALUMINUM DISK SET IN THE TOP OF AN 8" POURED CONCRETE CYLINDER 30" IN DEPTH AND IS FLUSH WITH THE GROUND.
 STA. 132+75.81, 45.79' LT.
 ELEV. 1036.450

0 CY OF TRANSVERSE BENCHES

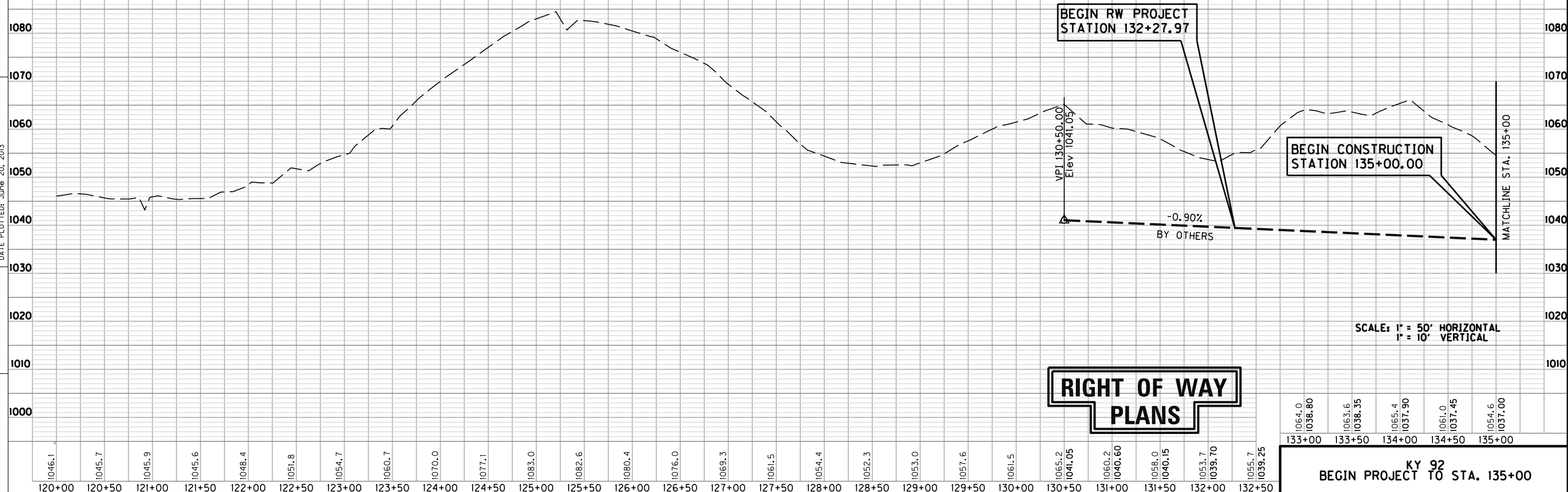

1064.0	1063.6	1065.4	1061.0	1054.6
1038.80	1038.35	1037.90	1037.45	1037.00
133+00	133+50	134+00	134+50	135+00

KY 92 DIVERSION #1
 P.I. 137+19.42
 $\Delta = 3^{\circ}44'17''$ LT
 T = 326.32'
 L = 652.41'
 R = 10000.00'
 E = 5.32'
 e = NC
 Runoff = See Sections
 Runout = See Sections
 DESIGN SPEED 45 MPH

KY. 1673
 P.I. 49+28.28
 $\Delta = 29^{\circ}27'20''$ RT
 T = 72.29'
 L = 141.38'
 R = 275.00'
 E = 9.34'
 e = RC
 Runoff = See Sections
 Runout = See Sections
 DESIGN SPEED 15 MPH

KY. 92
 P.I. 145+34.75
 $\Delta = 36^{\circ}53'05''$ RT
 T = 666.95'
 L = 1287.52'
 R = 2000.00'
 E = 108.28'
 e = 5.82%
 Runoff = 149
 Runout = 51
 DESIGN SPEED 55 MPH

HAMP CRIT HIGGINBOTHAM
 BETTIE RUTH JONES

HAMP CRIT HIGGINBOTHAM
 BETTIE RUTH JONES

HAMP CRIT HIGGINBOTHAM
 PATRICIA L. HIGGINBOTHAM (WF)
 (TOTAL TAKE)

HAMP CRIT HIGGINBOTHAM
 BETTIE RUTH JONES

BOBBY K. MAYS
 FREDIA MAYS (WF)

BOBBY K. MAYS
 FREDIA MAYS (WF)

BEARING / DISTANCES

5 - Arc = 781.37', R. = 1467.39'	14 - N 44°33'13" W - 71.51'
Chd. = S 76°48'04" E - 772.17'	15 - S 45°16'39" E - 46.26'
6 - S 82°02'53" W - 77.03'	16 - S 44°33'13" E - 95.87'
7 - S 87°19'44" W - 71.13'	17 - S 47°00'18" E - 80.47'
8 - S 89°28'00" W - 87.69'	18 - S 54°10'27" E - 81.80'
9 - N 84°53'31" W - 65.85'	19 - S 67°06'13" E - 68.05'
10 - N 75°21'15" W - 68.05'	20 - S 75°21'15" E - 72.72'
11 - N 67°06'13" W - 62.49'	21 - S 84°53'31" E - 69.83'
12 - N 54°10'27" W - 76.52'	22 - N 89°28'00" E - 89.72'
13 - N 47°00'18" W - 77.95'	23 - N 87°19'44" E - 72.10'
	24 - N 85°46'11" E - 75.07'
	25 - Arc = 2.38', R. = 1467.39'
	Chd. = N 87°53'52" W - 2.38'
	26 - N 11°23'31" W - 201.86'

**RIGHT OF WAY
 PLANS**

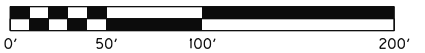

SCALE: 1"=50'

KY 92
 STA. 135+00 to STA. 150+00

FILE NAME: G:\ENGR\HDB5\01PHASE II\CAD\PLANS\ROW\13500PL.DGN
 USER: sdcgury
 DATE PLOTTED: June 20, 2013
 E-SHEET NAME:
 MicroStation v8.11.7.180

MicroStation v8.11.7.180 E-SHEET NAME: DATE PLOTTED: June 20, 2013 USER: sdcgury FILE NAME: G:\ENGR\H0185.01\PHASE II\CAD\PLANS\ROW\13500PR.DGN

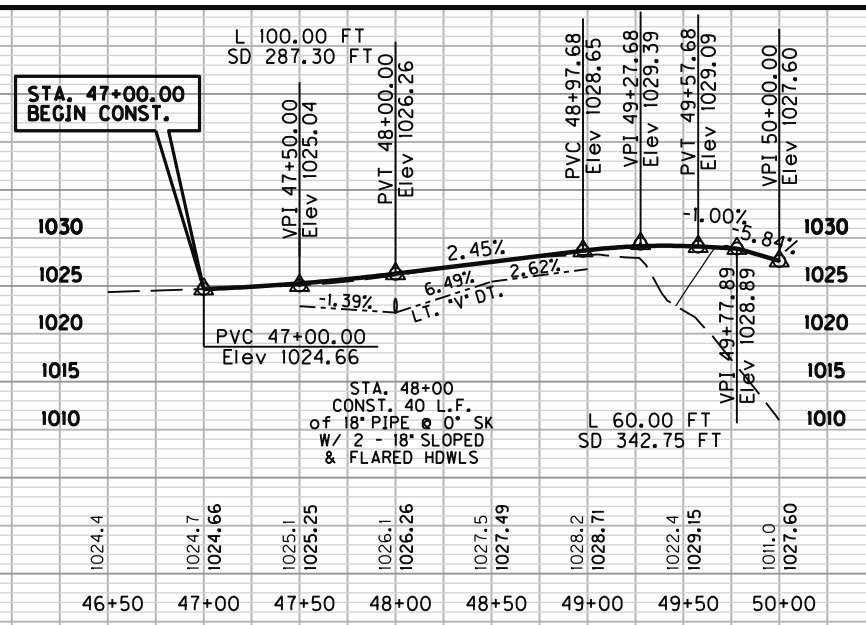

	STORM (YR)	RUNOFF (cfs)	HEADWATER ELEV (ft)
DESIGN	25	3.9	1023.57
CHECK	100	4.8	1023.77

BM#2
 3/4" ALUMINUM DISK SET IN THE TOP OF AN 8" POURED CONCRETE CYLINDER 30" IN DEPTH AND IS FLUSH WITH THE GROUND. STA. 138+18.61, 51.32' RT. ELEV. 1025.345

APPR. KY. 1673
 (LT. STA. 145+44.95)

	STORM (YR)	RUNOFF (cfs)	HEADWATER ELEV. (ft)	VELOCITY (fps)
DESIGN	50	1270.00	1013.29	2.1
CHECK	100	1430.00	1013.54	2.2

BRIDGE SITE 1
 STA. 143+23 @ 30° SKEW LT
 3 SPAN PCI BEAM - TYPE III
 (63.3-80-63.2)

END DIVERSION #1
 STA. 142+00.00

KY 1673 STA. 50+00.00=
 KY 92 STA. 145+44+95

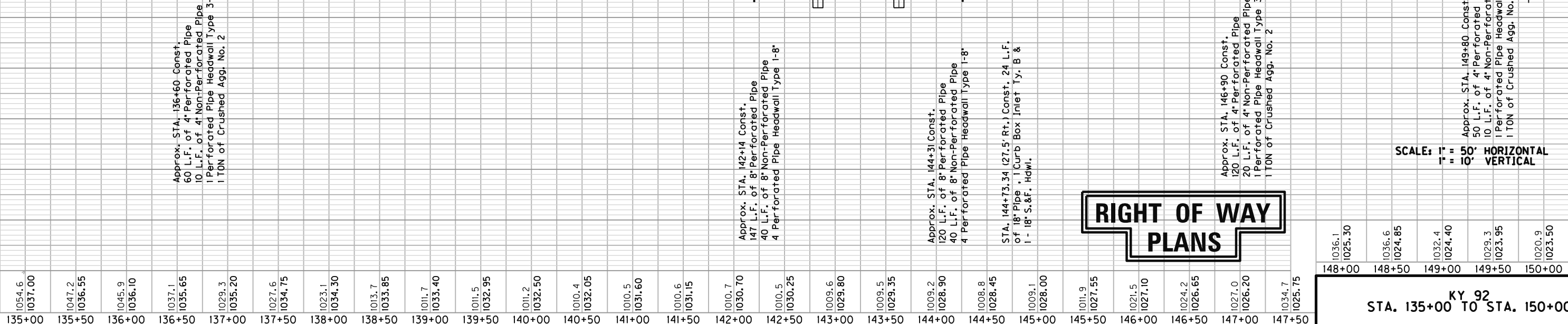
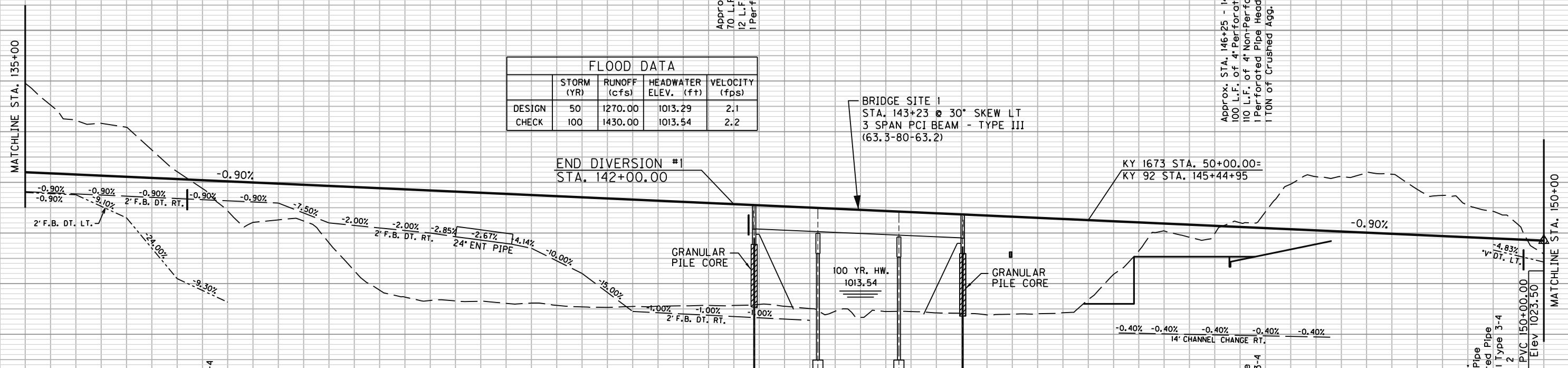

**RIGHT OF WAY
 PLANS**

1036.1 1025.30
 1036.6 1024.85
 1032.4 1024.40
 1029.3 1023.95
 1020.9 1023.50

148+00 148+50 149+00 149+50 150+00

KY 92
 STA. 135+00 TO STA. 150+00

4581 CY OF TRANSVERSE BENCHES

Approx. STA. 142+10 Const.
 70 L.F. of 4" Perforated Pipe
 12 L.F. of 4" Non-Perforated Pipe
 1 Perforated Pipe Headwall Type 2-4

Approx. STA. 146+25 - 147+25
 100 L.F. of 4" Perforated Pipe
 10 L.F. of 4" Non-Perforated Pipe
 1 Perforated Pipe Headwall Type 1-4
 1 TON of Crushed Agg. No. 2

Approx. STA. 149+80 Const.
 50 L.F. of 4" Perforated Pipe
 10 L.F. of 4" Non-Perforated Pipe
 1 Perforated Pipe Headwall Type 3-4
 1 TON of Crushed Agg. No. 2

KY 92
P.I. 145+34.75
 $\Delta = 36^\circ 53' 05''$ RT
T = 666.95'
L = 1287.52'
R = 2000.00'
E = 108.28'
e = 5.82%
Runoff = 149
Runout = 51
DESIGN SPEED 55 MPH

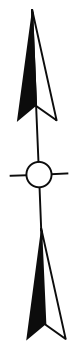

FILE NAME: G:\ENGR\HDIBS\01PHASE 11\CAD\PLANS\15000PL.DGN

USER: sdcgury DATE PLOTTED: June 20, 2013

MicroStation v8.11.7.180 E-SHEET NAME:

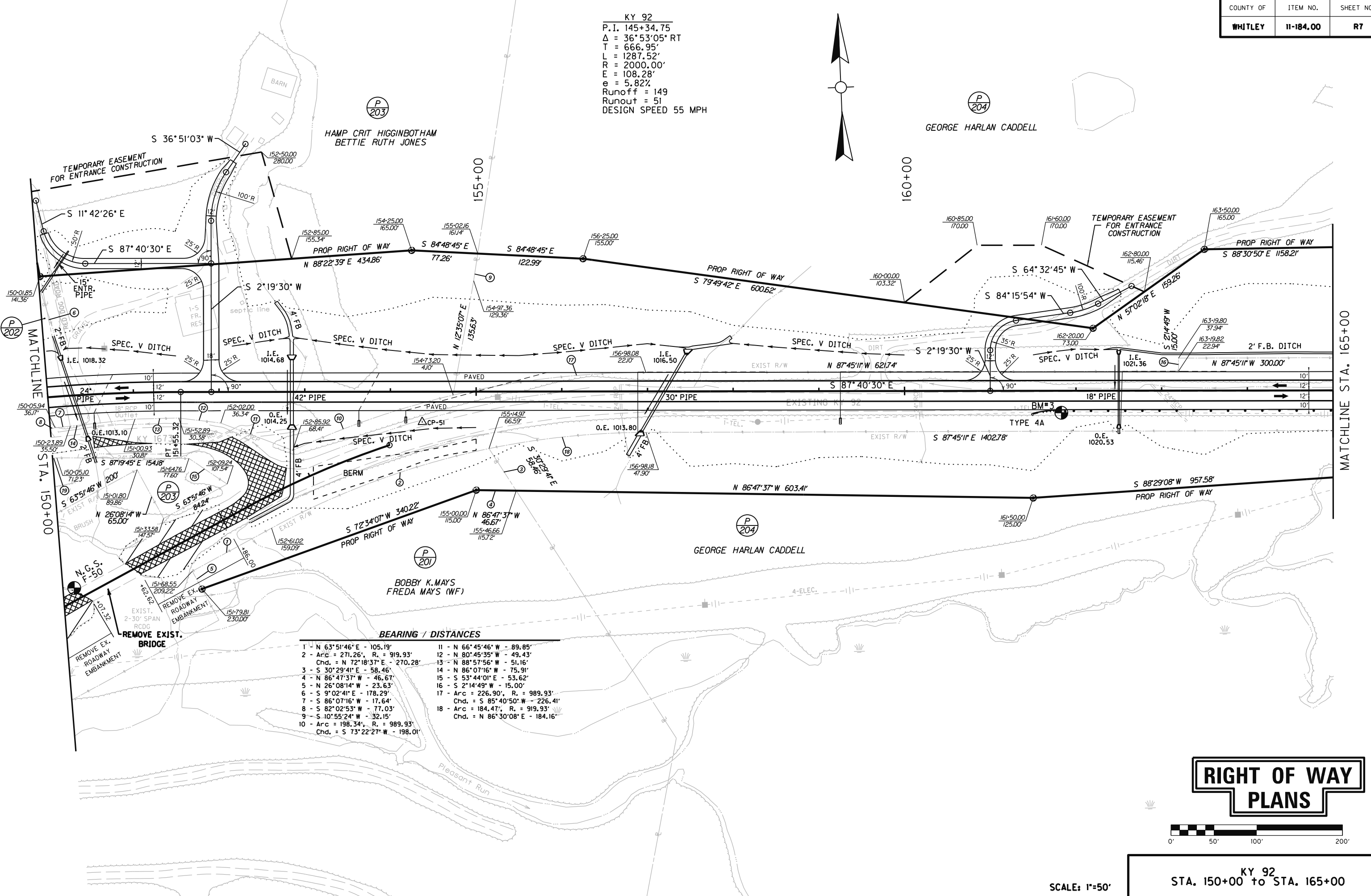

BEARING / DISTANCES

1 - N 63°51'46" E - 105.19'	11 - N 66°45'46" W - 89.85'
2 - Arc = 271.26', R. = 919.93'	12 - N 80°45'35" W - 49.43'
Chd. = N 72°18'37" E - 270.28'	13 - N 88°57'56" W - 51.16'
3 - S 30°29'41" E - 58.46'	14 - N 86°07'16" W - 75.91'
4 - N 86°47'37" W - 46.67'	15 - S 53°44'01" E - 53.62'
5 - N 26°08'14" W - 23.63'	16 - S 2°14'49" W - 15.00'
6 - S 9°02'41" E - 178.29'	17 - Arc = 226.90', R. = 989.93'
7 - S 86°07'16" W - 17.64'	Chd. = S 85°40'50" W - 226.41'
8 - S 82°02'53" W - 77.03'	18 - Arc = 184.47', R. = 919.93'
9 - S 10°55'24" W - 32.15'	Chd. = N 86°30'08" E - 184.16'
10 - Arc = 198.34', R. = 989.93'	
Chd. = S 73°22'27" W - 198.01'	

RIGHT OF WAY PLANS

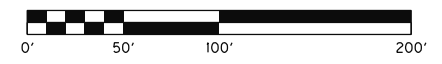

SCALE: 1"=50'
KY 92
STA. 150+00 to STA. 165+00

MicroStation v8.11.7.180 E-SHEET NAME: DATE PLOTTED: June 20, 2013 USER: sdcgcurty FILE NAME: G:\ENGR\H0185.01\PHASE I\ACAD\PLANS\ROW\1500PR.DGN

COUNTY OF	ITEM NO.	SHEET NO.
WHITLEY	11-184.00	R8

N.G.S. F-50 1935
 SET IN THE TOP OF THE NORTH END OF THE WEST ABUTMENT OF A 60' BRIDGE OVER MARSH CREEK, 12' NORTH OF THE CENTER LINE OF THE HIGHWAY AND ABOUT LEVEL WITH THE HIGHWAY.
 STA. 150+14.80, 224.24' RT.
 ELEV. 1014.580

BM#3
 3/4" ALUMINUM DISK SET IN THE TOP OF AN 8" POURED CONCRETE CYLINDER 30" IN DEPTH AND IS FLUSH WITH THE GROUND.
 STA. 161+83.01, 25.68' RT.
 ELEV. 1024.643

3817 CY OF TRANSVERSE BENCHES

FLOOD DATA STA. 150+30

	STORM (YR)	RUNOFF (cfs)	HEADWATER ELEV (ft)
DESIGN	25	15.7	1020.59
CHECK	100	19.6	1021.13

FLOOD DATA STA. 152+85

	STORM (YR)	RUNOFF (cfs)	HEADWATER ELEV (ft)
DESIGN	25	46.3	1018.49
CHECK	100	57.0	1019.20

FLOOD DATA STA. 157+20

	STORM (YR)	RUNOFF (cfs)	HEADWATER ELEV (ft)
DESIGN	25	29	1019.70
CHECK	100	36	1020.42

FLOOD DATA STA. 162+50

	STORM (YR)	RUNOFF (cfs)	HEADWATER ELEV (ft)
DESIGN	25	4.9	1022.84
CHECK	100	5.9	1023.04

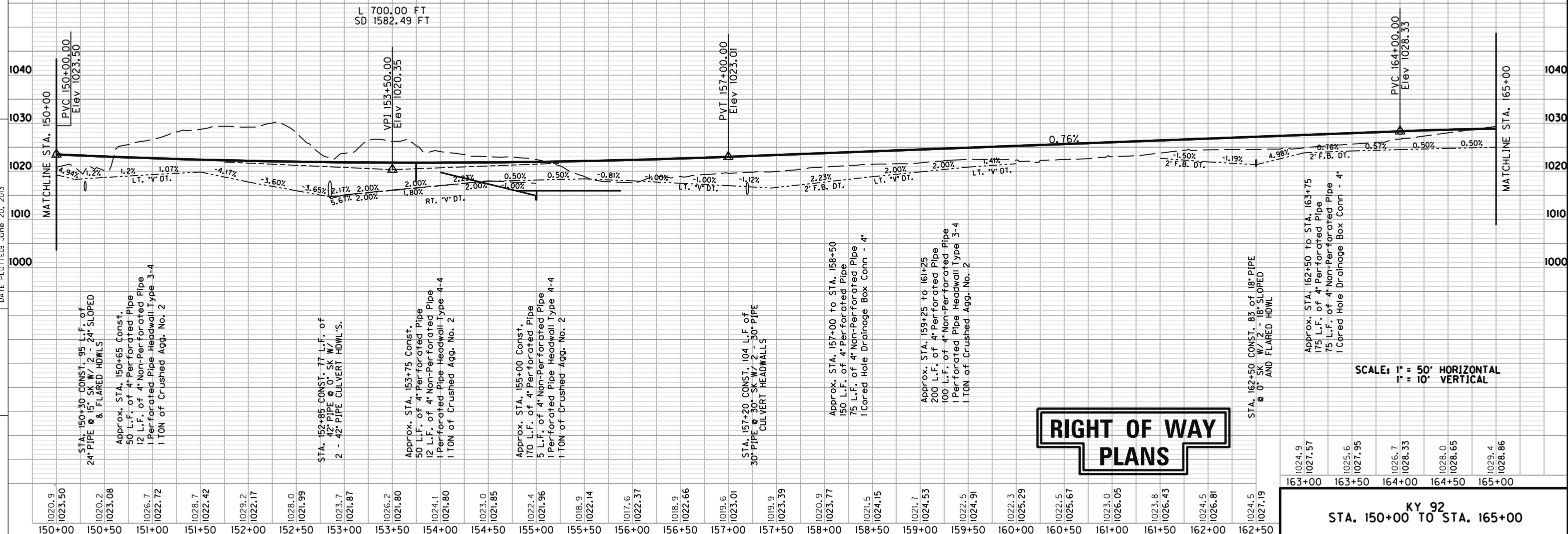

**RIGHT OF WAY
PLANS**

SCALE: 1" = 50' HORIZONTAL
 1" = 10' VERTICAL

1024.9	1027.57	1025.6	1027.95	1026.7	1028.33	1028.0	1028.65	1029.4	1028.86
163+00	163+50	164+00	164+50	165+00					

STA. 150+00 TO STA. 165+00

KY 92
 P.I. 181+36.88
 $\Delta = 49^\circ 53' 48''$ LT
 T = 1256.07'
 L = 2351.32'
 R = 2700.00'
 E = 277.87'
 e = 4.67%
 Runoff = 119
 Runout = 51
 DESIGN SPEED 55 MPH

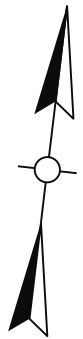

P
204

170+00 GEORGE HARLAN CADELL

175+00

MATCHLINE STA. 165+00

MATCHLINE STA. 180+00

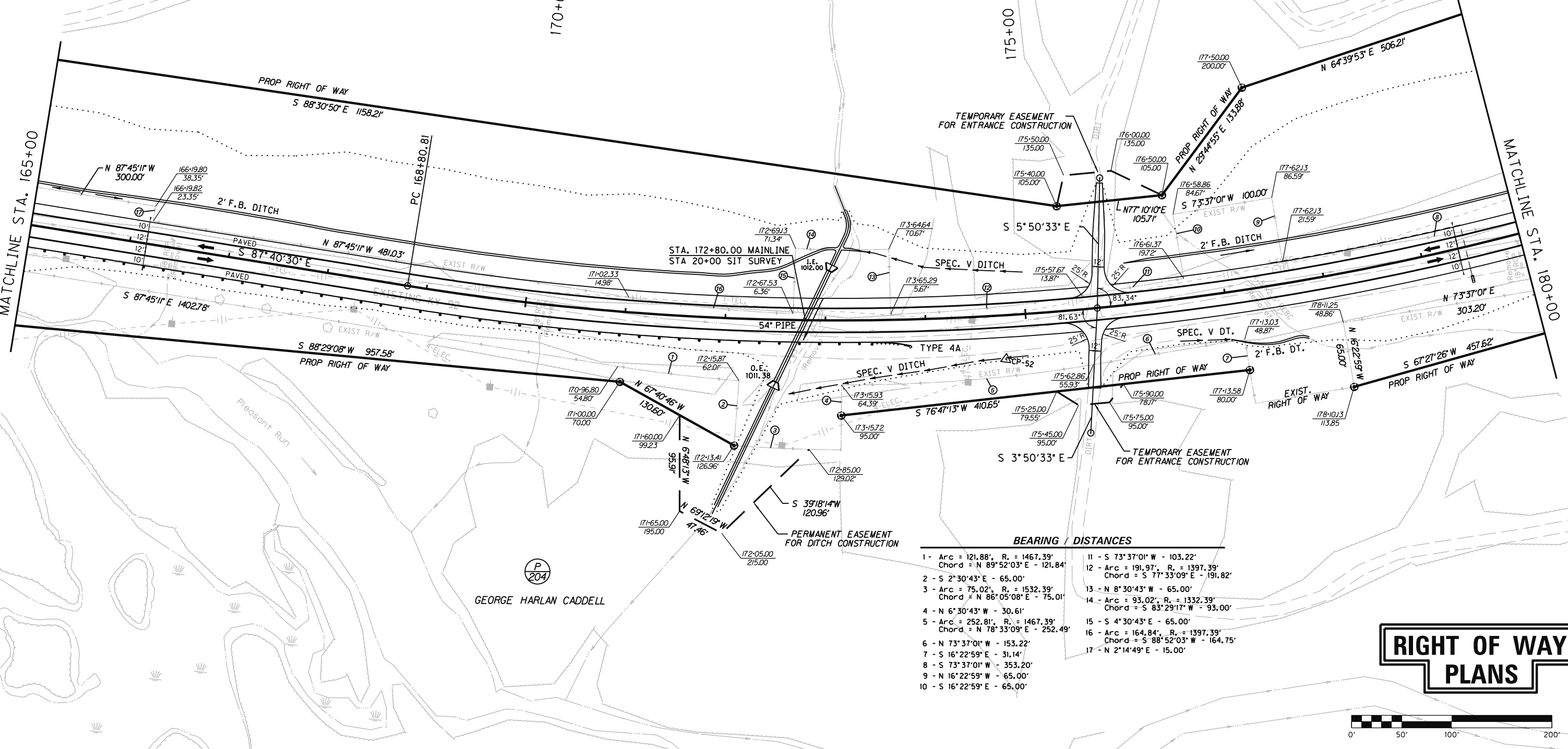

BEARING / DISTANCES

1 - Arc = 121.88', R. = 1467.39' Chord = N 89°52'03" E - 121.84'	11 - S 73°37'01" W - 103.22'
2 - S 2°30'43" E - 65.00'	12 - Arc = 191.97', R. = 1397.39' Chord = S 77°33'09" E - 191.82'
3 - Arc = 75.02', R. = 1532.39' Chord = N 86°05'08" E - 75.01'	13 - N 8°30'43" W - 65.00'
4 - N 6°30'43" W - 30.61'	14 - Arc = 93.02', R. = 1332.39' Chord = S 83°29'17" W - 93.00'
5 - Arc = 252.81', R. = 1467.39' Chord = N 78°33'09" E - 252.49'	15 - S 4°30'43" E - 65.00'
6 - N 73°37'01" W - 153.22'	16 - Arc = 164.84', R. = 1397.39' Chord = S 88°52'03" W - 164.75'
7 - S 16°22'59" E - 31.14'	17 - N 2°14'49" E - 15.00'
8 - S 73°37'01" W - 353.20'	
9 - N 16°22'59" E - 65.00'	
10 - S 16°22'59" E - 65.00'	

**RIGHT OF WAY
PLANS**

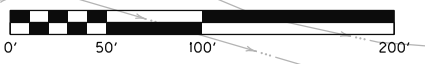

SCALE: 1"=50'

KY 92
STA. 165+00 to STA. 180+00

FILE NAME: G:\ENGR\HD85_01\PHASE II\CAD\PLANS\ROW\16500PL.DGN

USER: sdcgcty
DATE PLOTTED: June 20, 2013

E-SHEET NAME:

MicroStation v8.11.7.180

BM#4
 3/4" ALUMINUM DISK SET IN THE TOP OF AN 8" POURED CONCRETE CYLINDER 30" IN DEPTH AND IS FLUSH WITH THE GROUND. STA. 168+31.63, 25.93' RT. ELEV. 1026.588

0 CY OF TRANSVERSE BENCHES

FLOOD DATA STA. 172+95			
	STORM (YR)	RUNOFF (cfs)	HEADWATER ELEV (ft)
DESIGN	25	90	1017.00
CHECK	100	110	1017.85

MicroStation v8.11.7.180 E-SHEET NAME: FILE NAME: G:\ENGR\1085.0\PHASE I\ACAD\PLANS\ROW\16500PR.DGN
 USER: sdcgcty DATE PLOTTED: June 20, 2013

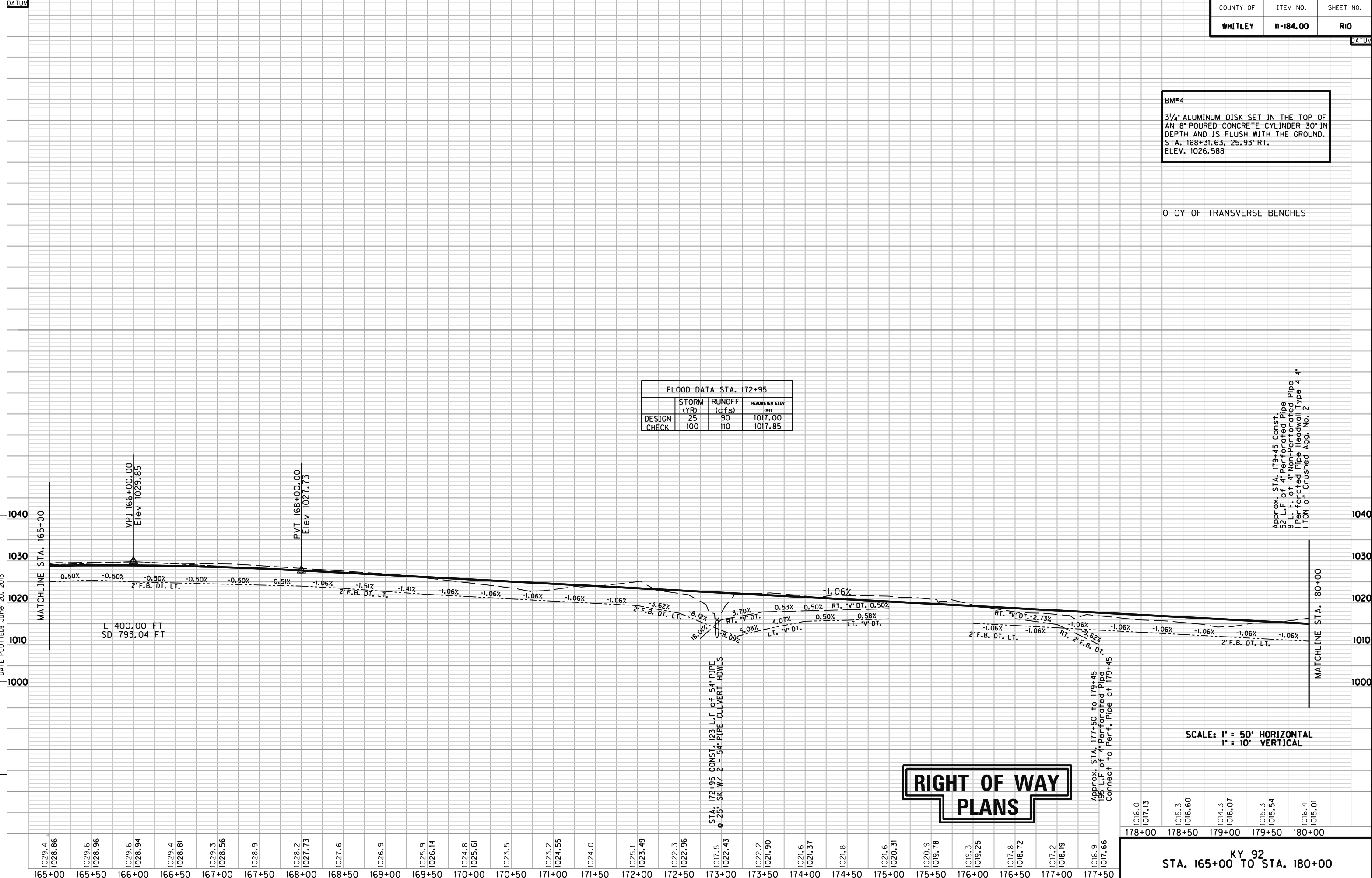

Approx. STA. 179+45 Const.
 52 L.F. of 4" Perforated Pipe
 8 L.F. of 4" Non-Perforated Pipe
 1 Perforated Pipe Headwall Type 4-4"
 1 TON of Crushed Agg. No. 2

Approx. STA. 177+50 to 179+45
 195 L.F. of 4" Perforated Pipe
 Connect to Perf. Pipe at 179+45

SCALE: 1" = 50' HORIZONTAL
 1" = 10' VERTICAL

**RIGHT OF WAY
 PLANS**

1016.0	1015.3	1014.3	1015.3	1016.4
1017.13	1016.60	1016.07	1015.54	1015.01
178+00	178+50	179+00	179+50	180+00

STA. 165+00 TO STA. 180+00
 KY 92

KY 92
 P.I. 181+36.88
 $\Delta = 49^\circ 53' 48''$ LT
 T = 1256.07'
 L = 2351.32'
 R = 2700.00'
 E = 277.87'
 e = 4.67%
 Runoff = 119
 Runout = 51
 DESIGN SPEED 55 MPH

P
204

GEORGE HARLAN CADDELL

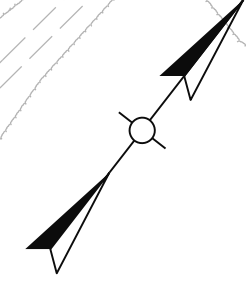

FILE NAME: G:\ENGR\HDB5_01\PHASE II\CAD\PLANS\ROW\18000PL.DGN
 USER: sdcgcty
 DATE PLOTTED: June 20, 2013
 E-SHEET NAME:
 MicroStation v8.11.7.180

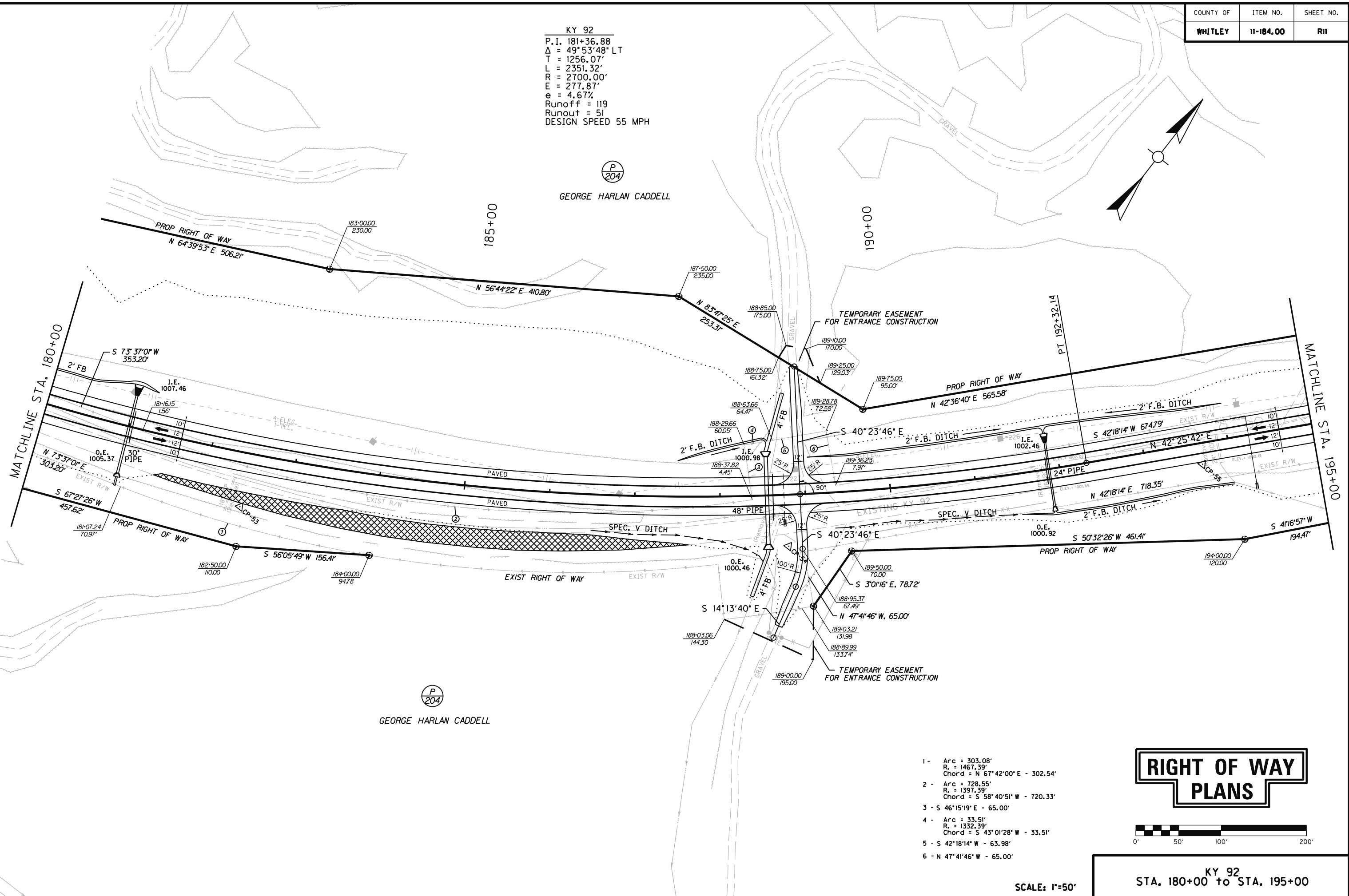

P
204

GEORGE HARLAN CADDELL

- 1 - Arc = 303.08'
R_c = 1467.39'
Chord = N 67°42'00" E - 302.54'
- 2 - Arc = 728.55'
R_c = 1397.39'
Chord = S 58°40'51" W - 720.33'
- 3 - S 46°15'19" E - 65.00'
- 4 - Arc = 33.51'
R_c = 1332.39'
Chord = S 43°01'28" W - 33.51'
- 5 - S 42°18'14" W - 63.98'
- 6 - N 47°41'46" W - 65.00'

RIGHT OF WAY
 PLANS

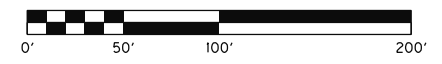

SCALE: 1"=50'

KY 92
 STA. 180+00 to STA. 195+00

MicroStation v8.11.7.180 E-SHEET NAME: USER: sdcgcky DATE PLOTTED: June 20, 2013 FILE NAME: G:\ENGR\H0185.0\PHASE I\ACAD\PLANS\ROW\8000PR.DGN

FLOOD DATA STA. 181+00			
	STORM (YR)	RUNOFF (cfs)	HEADWATER ELEV (ft)
DESIGN	25	19	1009.64
CHECK	100	23	1009.96

FLOOD DATA STA. 188+55			
	STORM (YR)	RUNOFF (cfs)	HEADWATER ELEV (ft)
DESIGN	25	60	1005.12
CHECK	100	74	1005.80

FLOOD DATA STA. 191+87.6			
	STORM (YR)	RUNOFF (cfs)	HEADWATER ELEV (ft)
DESIGN	25	14	1004.56
CHECK	100	17	1004.93

0 CY OF TRANSVERSE BENCHES



RIGHT OF WAY PLANS

SCALE: 1" = 50' HORIZONTAL
1" = 10' VERTICAL

1005.6	1005.3	1005.1	1004.9	1004.7
1007.53	1007.28	1007.03	1006.78	1006.53
193+00	193+50	194+00	194+50	195+00

KY 92
STA. 180+00 TO STA. 195+00

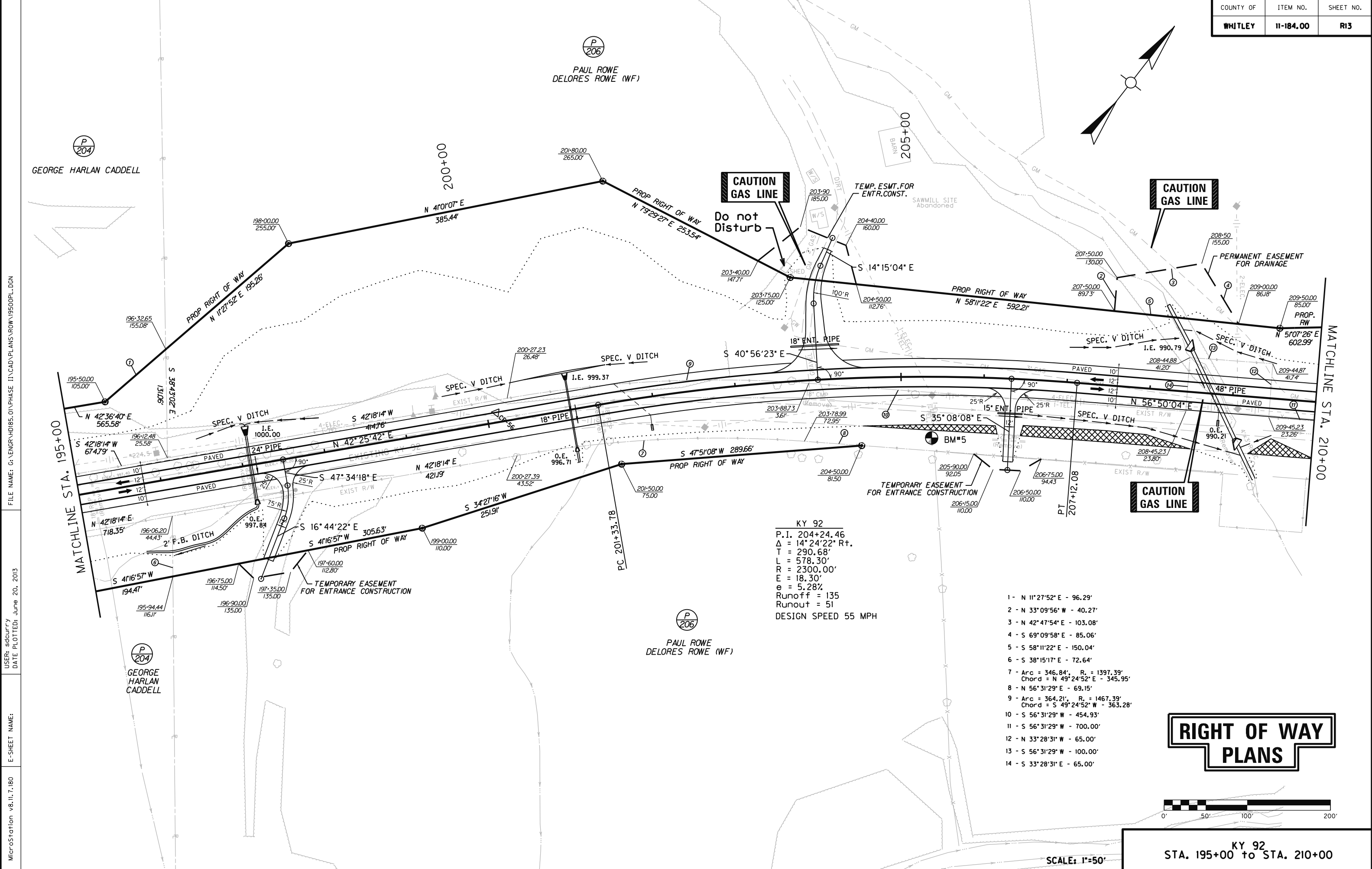
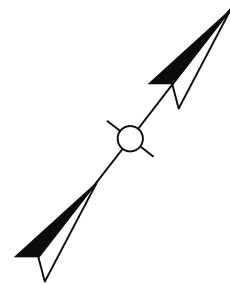

CAUTION GAS LINE

Do not Disturb

CAUTION GAS LINE

CAUTION GAS LINE

KY 92
 P.I. 204+24.46
 $\Delta = 14^\circ 24' 22''$ Rt.
 T = 290.68'
 L = 578.30'
 R = 2300.00'
 E = 18.30'
 e = 5.28%
 Runoff = 135
 Runout = 51
 DESIGN SPEED 55 MPH

- 1 - N 11°27'52" E - 96.29'
- 2 - N 33°09'56" W - 40.27'
- 3 - N 42°47'54" E - 103.08'
- 4 - S 69°09'58" E - 85.06'
- 5 - S 58°11'22" E - 150.04'
- 6 - S 38°15'17" E - 72.64'
- 7 - Arc = 346.84', R. = 1397.39'
Chord = N 49°24'52" E - 345.95'
- 8 - N 56°31'29" E - 69.15'
- 9 - Arc = 364.21', R. = 1467.39'
Chord = S 49°24'52" W - 363.28'
- 10 - S 56°31'29" W - 454.93'
- 11 - S 56°31'29" W - 700.00'
- 12 - N 33°28'31" W - 65.00'
- 13 - S 56°31'29" W - 100.00'
- 14 - S 33°28'31" E - 65.00'

RIGHT OF WAY PLANS

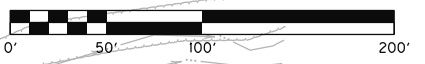

SCALE: 1"=50'

KY 92
 STA. 195+00 to STA. 210+00

FILE NAME: G:\ENGR\HD185_01\PHASE 1\ACAD\PLANS\ROW19500PL.DGN

USER: sdcgcty
 DATE PLOTTED: June 20, 2013

E-SHEET NAME:

MicroStation v8.11.7.180

P 204
 GEORGE HARLAN CADDELL

P 206
 PAUL ROWE
 DELORES ROWE (WF)

P 204
 GEORGE HARLAN CADDELL

P 206
 PAUL ROWE
 DELORES ROWE (WF)

MicroStation v8.11.7.180 E-SHEET NAME: DATE PLOTTED: June 20, 2013 USER: sdcgury FILE NAME: G:\ENGR\H0185.0\PHASE II\CAD\PLANS\ROW\19500PR.DGN

COUNTY OF	ITEM NO.	SHEET NO.
WHITLEY	11-184.00	R14

BM#5
 3/4" ALUMINUM DISK SET IN THE TOP OF AN 8" POURED CONCRETE CYLINDER 30" IN DEPTH AND IS FLUSH WITH THE GROUND.
 STA. 205+37.14, 73.60' RT.
 ELEV. 1005.168

0 CY OF TRANSVERSE BENCHES

	STORM (YR)	RUNOFF (cfs)	HEADWATER ELEV (ft)
DESIGN	25	9	1001.53
CHECK	100	11	1001.75

	STORM (YR)	RUNOFF (cfs)	HEADWATER ELEV (ft)
DESIGN	25	6.9	1000.36
CHECK	100	8.5	1000.50

	STORM (YR)	RUNOFF (cfs)	HEADWATER ELEV (ft)
DESIGN	25	68	995.33
CHECK	100	84	996.31

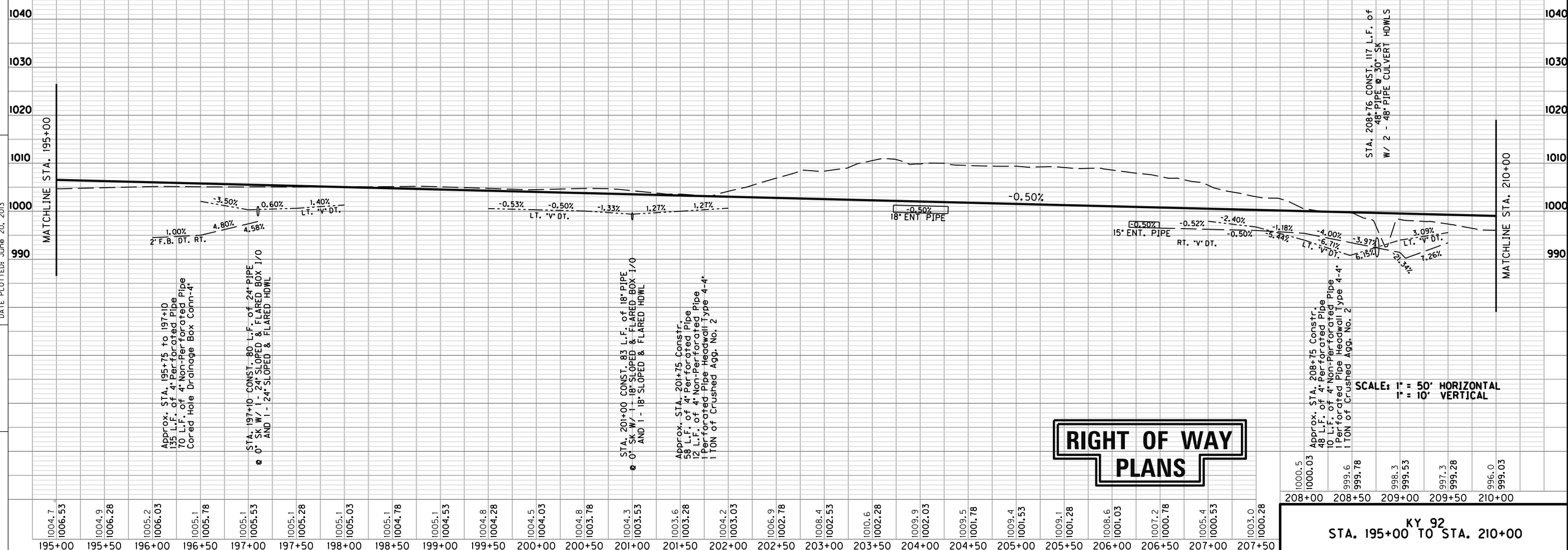

RIGHT OF WAY PLANS

SCALE: 1" = 50' HORIZONTAL
 1" = 10' VERTICAL

1000.5	1000.03	1000.03	1000.03
999.6	999.78	998.3	999.53
997.3	999.28	996.0	999.03

STA. 195+00 TO STA. 210+00
 KY 92

COUNTY OF	ITEM NO.	SHEET NO.
WHITLEY	11-184.00	R15

- 1 - N 33°28'31" W - 65.00'
- 2 - S 56°31'29" W - 150.00'
- 3 - S 33°28'31" E - 65.00'

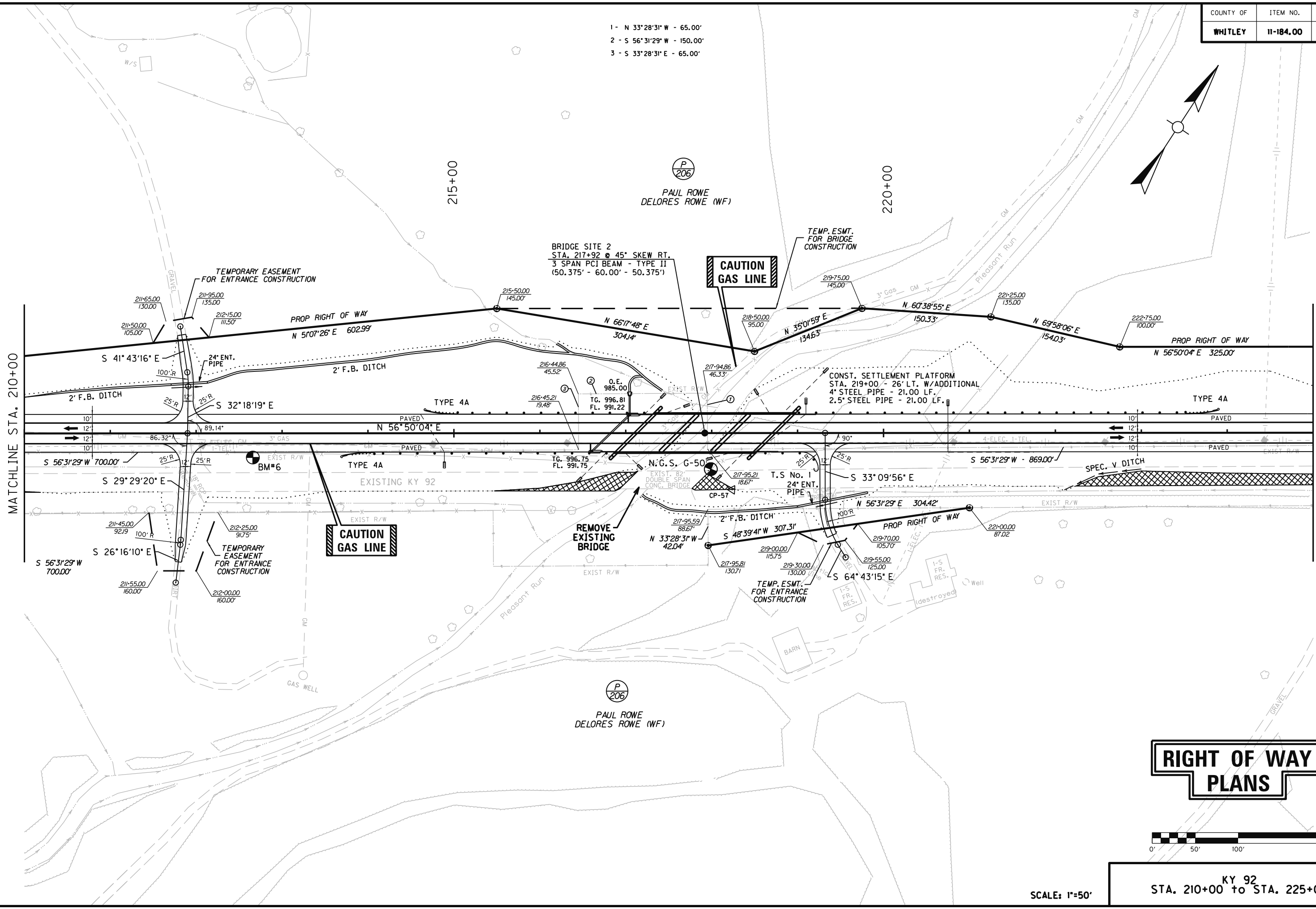
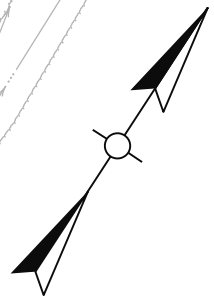

MATCHLINE STA. 210+00

MATCHLINE STA. 225+00

RIGHT OF WAY PLANS

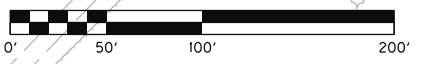

KY 92
STA. 210+00 to STA. 225+00

SCALE: 1"=50'

FILE NAME: G:\ENGR\HD85.0\PHASE II\CAD\PLANS\ROW\21000PL.DGN

USER: HOYSON
DATE PLOTTED: June 20, 2013

E-SHEET NAME:

MicroStation v8.11.7.180

N.G.S. G-50 1935
 SET IN THE TOP OF THE NORTH END OF THE EAST ABUTMENT OF AN 80' BRIDGE OVER PLEASANT RUN CREEK, 12' NORTH OF THE CENTER LINE OF THE HIGHWAY AND ABOUT LEVEL WITH THE GROUND.
 STA. 217+98.96, 42.03' RT.
 ELEV. 986.103

BM#6
 3/4" ALUMINUM DISK SET IN THE TOP OF AN 8" POURED CONCRETE CYLINDER 30" IN DEPTH AND IS FLUSH WITH THE GROUND.
 STA. 212+65.95, 28.19' RT.
 ELEV. 987.851

FLOOD DATA				
	STORM (YR)	RUNOFF (cfs)	HEADWATER ELEV. (ft)	VELOCITY (fps)
DESIGN	50	1500.00	980.39	5.8
CHECK	100	1710.00	980.92	5.9

0 CY OF TRANSVERSE BENCHES

MicroStation v8.11.7.483 E-SHEET NAME: DATE PLOTTED: June 09, 12:01:03 FILE NAME: G:\ENGR\H0185.01\PHASE 1\ACAD\PROJECTS\ENR\H0185\01\PHASE 1.DWG

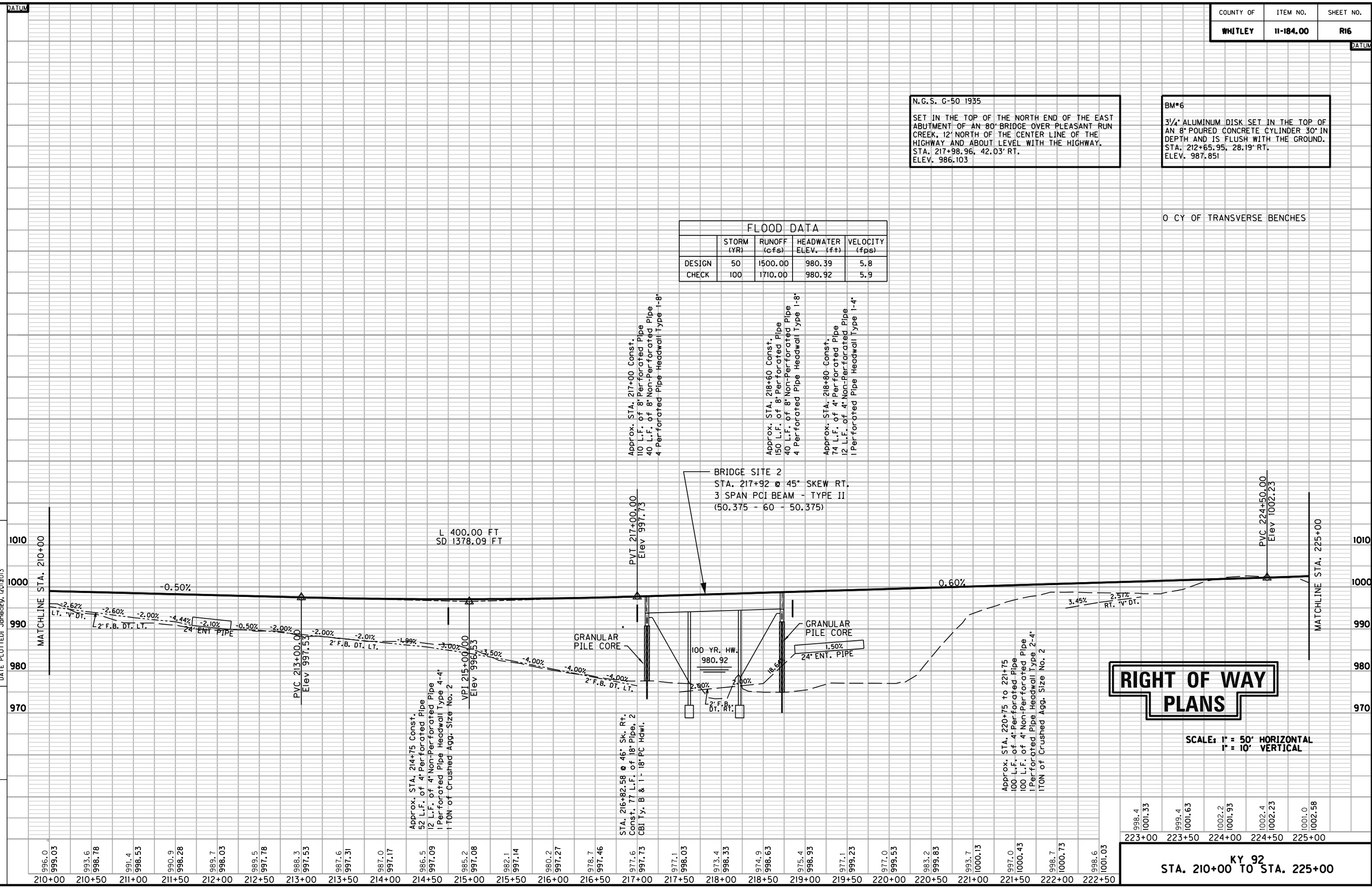

RIGHT OF WAY PLANS

SCALE: 1" = 50' HORIZONTAL
 1" = 10' VERTICAL

998.4 1001.33	999.4 1001.63	1002.2 1001.93	1002.4 1002.23	1001.0 1002.58
223+00	223+50	224+00	224+50	225+00

KY 92
 STA. 210+00 TO STA. 225+00

PROPERTY OWNERS
P 262 - DALE SNYDER

BEARING / DISTANCES	
1 - S 71°47'24" W, 165.20'	13 - N 33°28'31" W - 65.00'
2 - S 74°06'11" W, 97.19'	14 - S 56°31'29" W - 100.00'
3 - S 59°07'34" W - 128.65'	15 - N 56°31'29" E - 48.98'
4 - S 21°44'15" E - 5.86'	16 - S 34°15'07" E - 33.64'
5 - Arc = 119.15', R = 1004.93'	17 - S 56°50'04" W - 49.44'
Chd. = S 64°51'58" W - 119.08'	18 - N 33°28'31" W - 33.37'
6 - S 28°31'50" E - 15.00'	19 - S 10°42'52" E, 55.63'
7 - Arc = 85.43', R = 989.93'	20 - Arc = 124.79', R = 989.93'
Chd. S 58°59'50" W - 85.40'	Chd. = S 77°04'50" W - 124.70'
8 - S 56°31'29" W - 411.66'	21 - N 16°31'50" W - 15.00'
9 - N 33°28'31" W - 65.00'	22 - Arc = 91.33', R = 1004.93'
10 - S 56°31'29" W - 100.00'	Chd. = S 70°51'58" W - 91.29'
11 - S 33°28'31" E - 65.00'	23 - N 74°06'11" E, 25.88'
12 - S 56°31'29" W - 204.18'	24 - S 50°53'29" W, 134.97'

CAMPBELL ROAD
P.I. 47+36.67
Δ = 22°47'03" Lt.
T = 50.37'
L = 99.41'
R = 250.00'
E = 5.02'
e = N/A
DESIGN SPEED 15 MPH

FILE NAME: G:\ENGR\HDIBS\01PHASE\1\CAD\PLANS\ROW\22500PL.DGN
 USER: sdcgcty
 DATE PLOTTED: June 20, 2013
 E-SHEET NAME:
 MicroStation v8.11.7.180

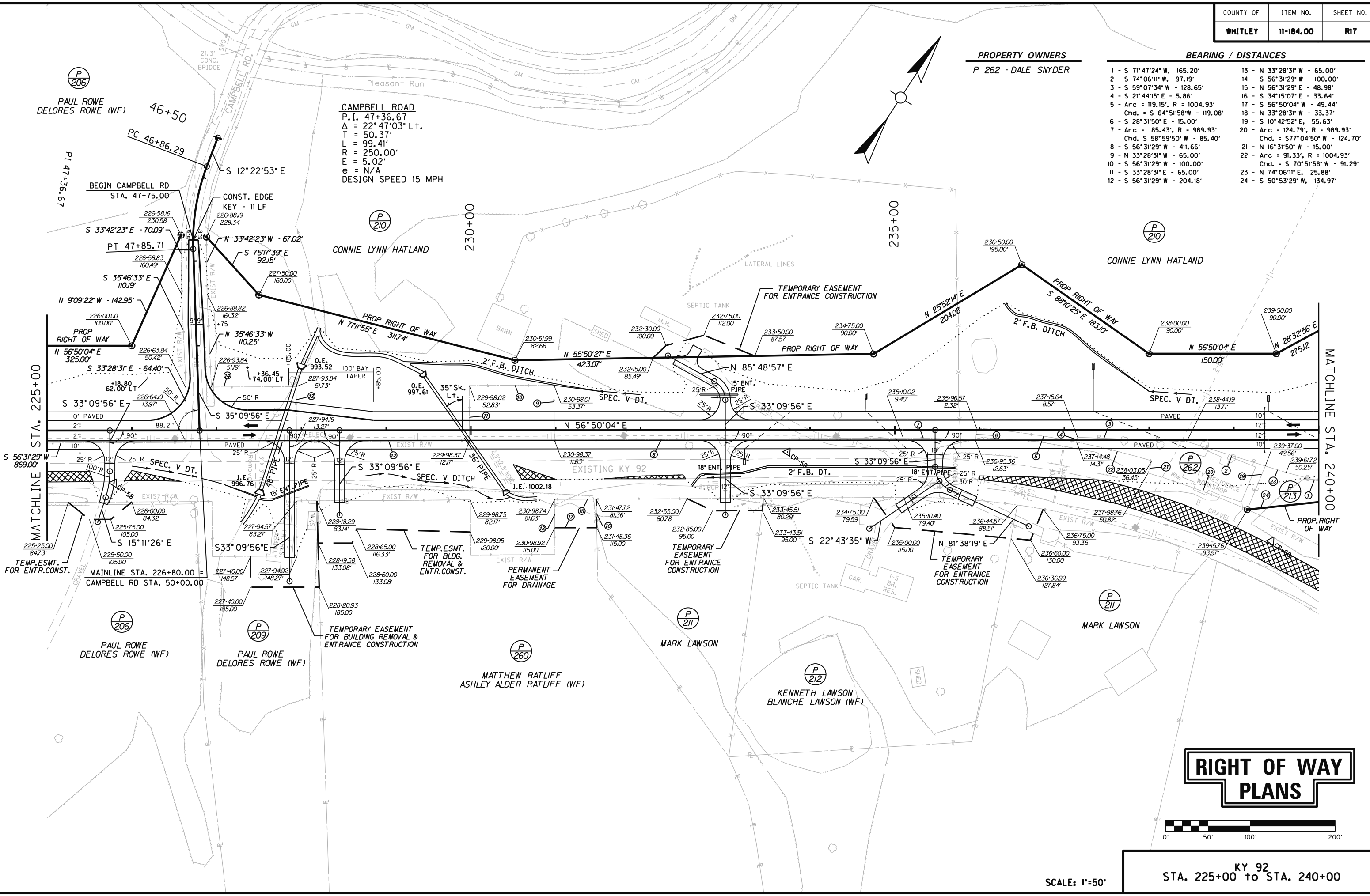

RIGHT OF WAY PLANS

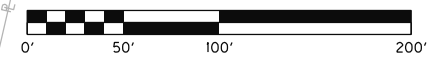

SCALE: 1"=50'

KY 92
STA. 225+00 to STA. 240+00

MicroStation v8.11.7.180 E-SHEET NAME: USER: sdcgury DATE PLOTTED: June 20, 2013 FILE NAME: G:\ENGR\H185.01\PHASE I\ACAD\PLANS\ROW\22500PR.DGN

COUNTY OF	ITEM NO.	SHEET NO.
WHITLEY	11-184.00	R18

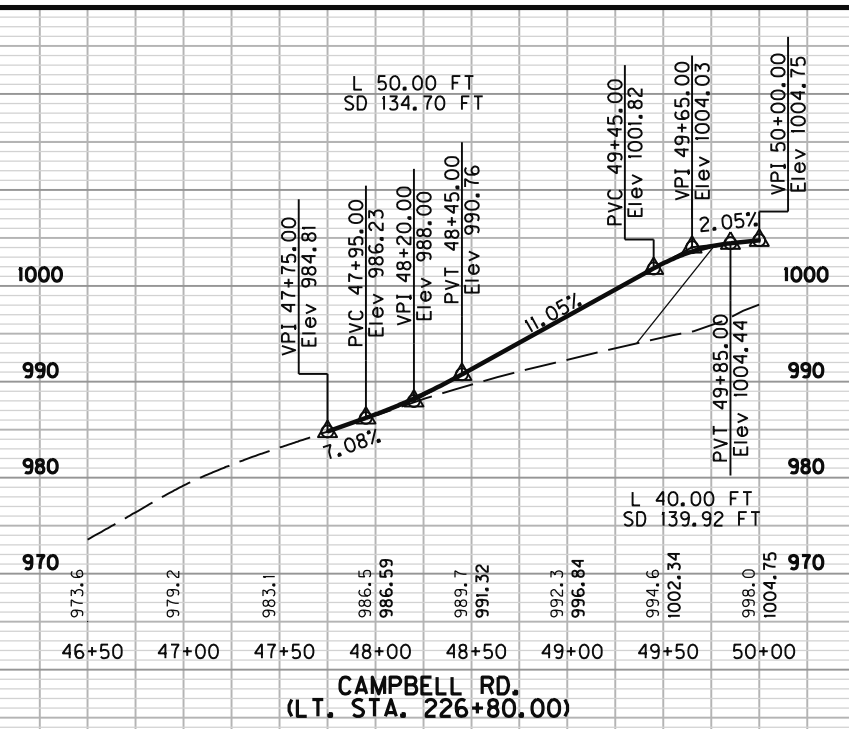

	STORM (YR)	RUNOFF (cfs)	HEADWATER ELEV (ft)
DESIGN	25	75.1	1000.75
CHECK	100	91.3	1001.45

	STORM (YR)	RUNOFF (cfs)	HEADWATER ELEV (ft)
DESIGN	25	32.6	1004.95
CHECK	100	39.8	1005.40

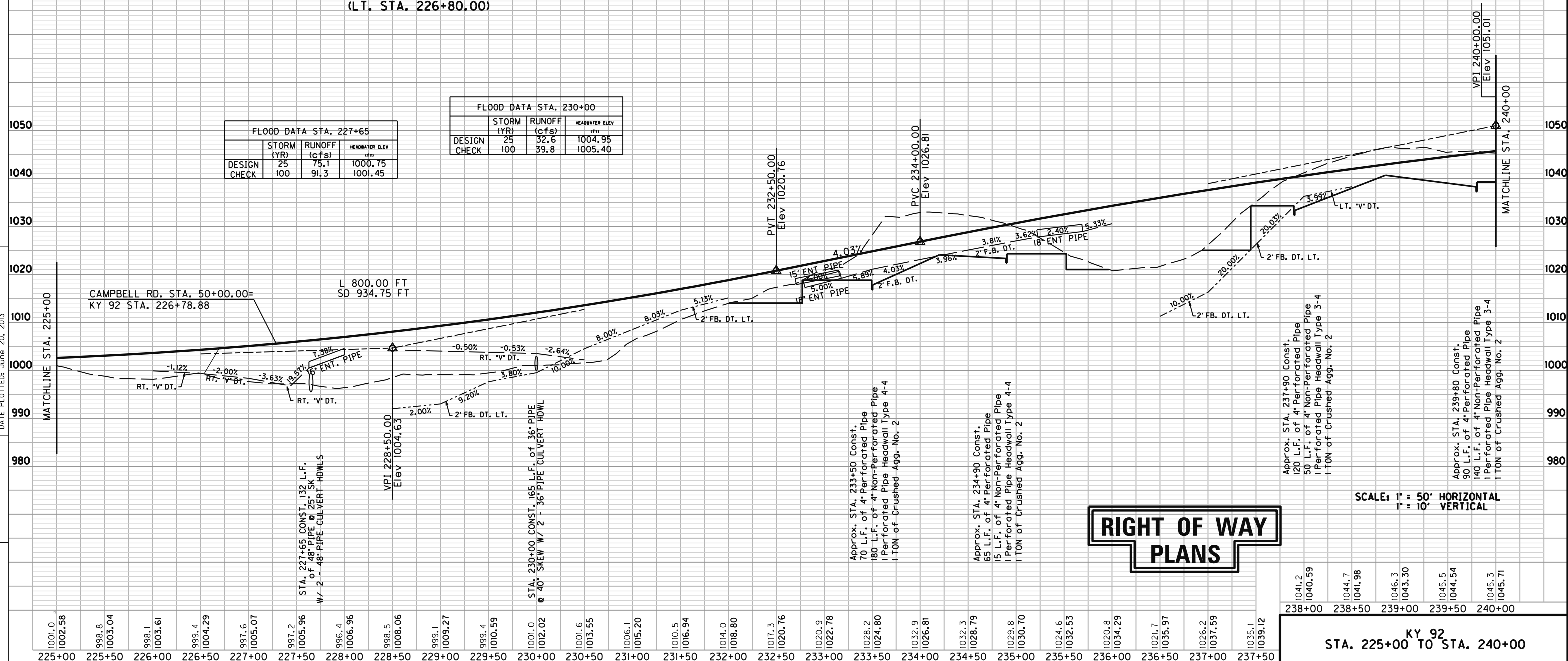

RIGHT OF WAY PLANS

SCALE: 1" = 50' HORIZONTAL
1" = 10' VERTICAL

1041.2	1044.7	1046.3	1045.5	1045.3
1040.59	1041.98	1043.30	1044.54	1045.71
238+00	238+50	239+00	239+50	240+00

KY 92
STA. 225+00 TO STA. 240+00

10560 CY OF TRANSVERSE BENCHES

L 1200.00 FT
SD 856.19 FT

Approx. STA. 233+50 Const.
70 L.F. of 4" Perforated Pipe
180 L.F. of 4" Non-Perforated Pipe
1 Perforated Pipe Headwall Type 4-4
1 TON of Crushed Agg. No. 2

Approx. STA. 234+90 Const.
65 L.F. of 4" Perforated Pipe
15 L.F. of 4" Non-Perforated Pipe
1 Perforated Pipe Headwall Type 4-4
1 TON of Crushed Agg. No. 2

Approx. STA. 237+90 Const.
120 L.F. of 4" Perforated Pipe
50 L.F. of 4" Non-Perforated Pipe
1 Perforated Pipe Headwall Type 3-4
1 TON of Crushed Agg. No. 2

Approx. STA. 239+80 Const.
90 L.F. of 4" Perforated Pipe
140 L.F. of 4" Non-Perforated Pipe
1 Perforated Pipe Headwall Type 3-4
1 TON of Crushed Agg. No. 2

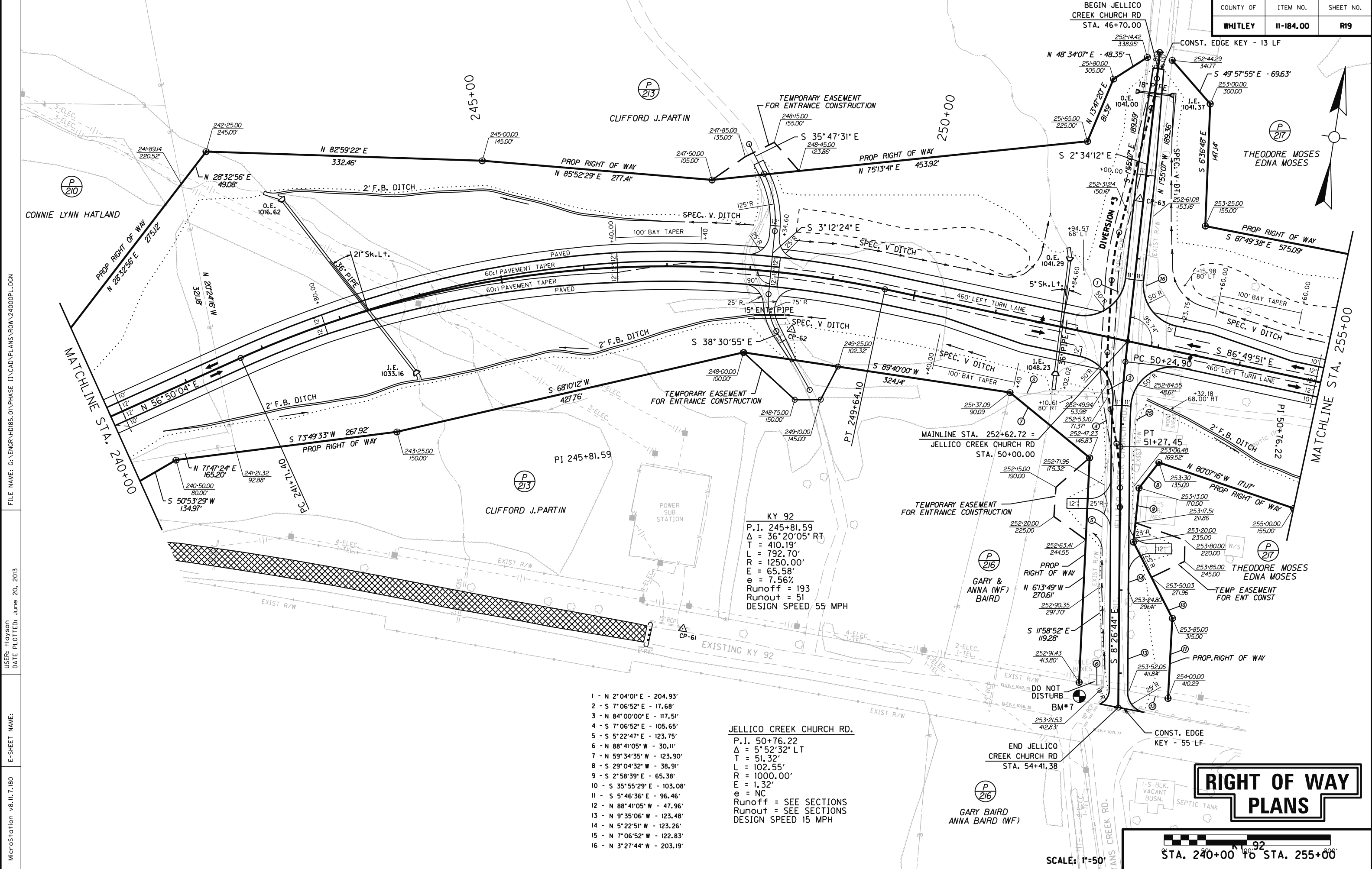

FILE NAME: G:\ENGR\HDIB5.0\PHASE 1\ACAD\PLANS\ROW\24000PL.DGN
 USER: HOYSON
 DATE PLOTTED: June 20, 2013
 E-SHEET NAME:
 MicroStation v8.11.7.180

- 1 - N 2°04'01" E - 204.93'
- 2 - S 7°06'52" E - 17.68'
- 3 - N 84°00'00" E - 117.51'
- 4 - S 7°06'52" E - 105.65'
- 5 - S 5°22'47" E - 123.75'
- 6 - N 88°41'05" W - 30.11'
- 7 - N 59°34'35" W - 123.90'
- 8 - S 29°04'32" W - 38.91'
- 9 - S 2°58'39" E - 65.38'
- 10 - S 35°55'29" E - 103.08'
- 11 - S 5°46'36" E - 96.46'
- 12 - N 88°41'05" W - 47.96'
- 13 - N 9°35'06" W - 123.48'
- 14 - N 5°22'51" W - 123.26'
- 15 - N 7°06'52" W - 122.83'
- 16 - N 3°27'44" W - 203.19'

JELICO CREEK CHURCH RD.
 P.I. 50+76.22
 $\Delta = 5^\circ 52' 32''$ LT
 T = 51.32'
 L = 102.55'
 R = 1000.00'
 E = 1.32'
 e = NC
 Runoff = SEE SECTIONS
 Runout = SEE SECTIONS
 DESIGN SPEED 15 MPH

RIGHT OF WAY PLANS

SCALE: 1"=50'
 STA. 240+00 TO STA. 255+00

MicroStation v8.11.7.180 E-SHEET NAME: DATE PLOTTED: June 20, 2013 USER: sdcgcurry FILE NAME: G:\ENGR\H085.01\PHASE I\ACAD\PLANS\ROW\2400PR.DGN

COUNTY OF	ITEM NO.	SHEET NO.
WHITLEY	11-184.00	R20

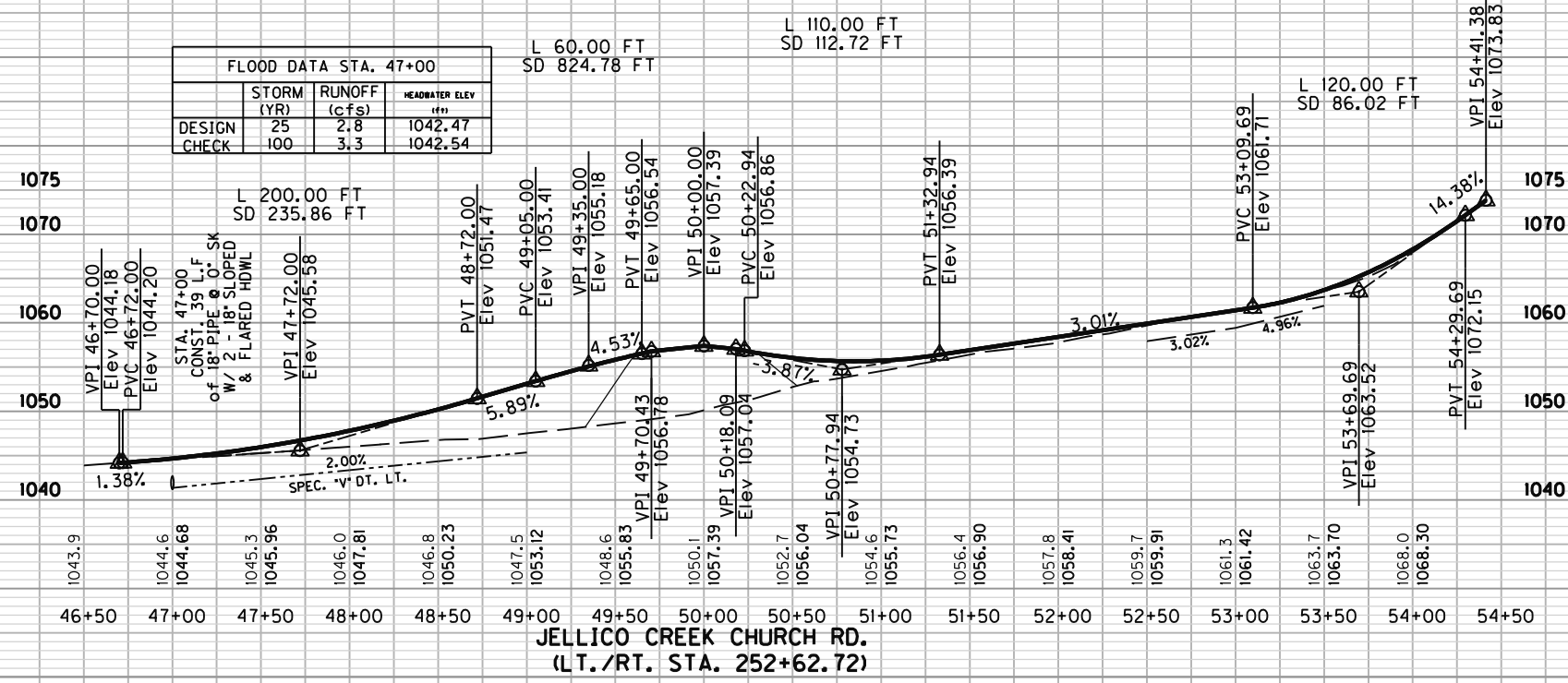

BM#7
 3/4" ALUMINUM DISK SET IN THE TOP OF AN 8" POURED CONCRETE CYLINDER 30" IN DEPTH AND IS FLUSH WITH THE GROUND. STA. 252+95.11, 430.11" RT. ELEV. 1073.438

0 CY OF TRANSVERSE BENCHES

DESIGN CHECK	STORM (YR)	RUNOFF (cfs)	HEADWATER ELEV (ft)
	25	44.0	1036.60
	100	53.8	1037.34

DESIGN CHECK	STORM (YR)	RUNOFF (cfs)	HEADWATER ELEV (ft)
	25	32.8	1050.98
	100	40.5	1051.46

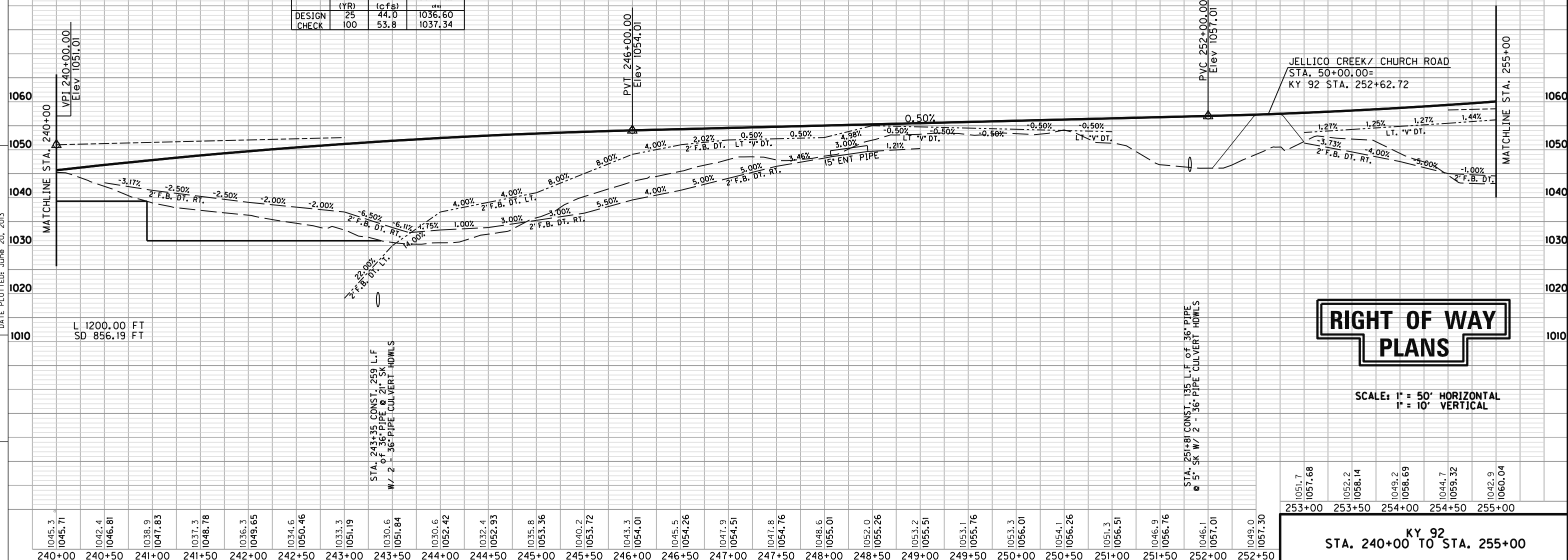

RIGHT OF WAY PLANS

SCALE: 1" = 50' HORIZONTAL
 1" = 10' VERTICAL

1051.7	1057.68	1052.2	1058.14	1049.2	1058.69	1044.7	1059.32	1042.9	1060.04
253+00	253+50	254+00	254+50	255+00					

KY 92
 STA. 240+00 TO STA. 255+00

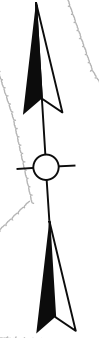

FILE NAME: G:\ENGR\HD185_01\PHASE II\CAD\PLANS\ROW\25500PL.DGN
 USER: HOYSON
 DATE PLOTTED: June 20, 2013
 E-SHEET NAME:
 MicroStation v8.11.7.180

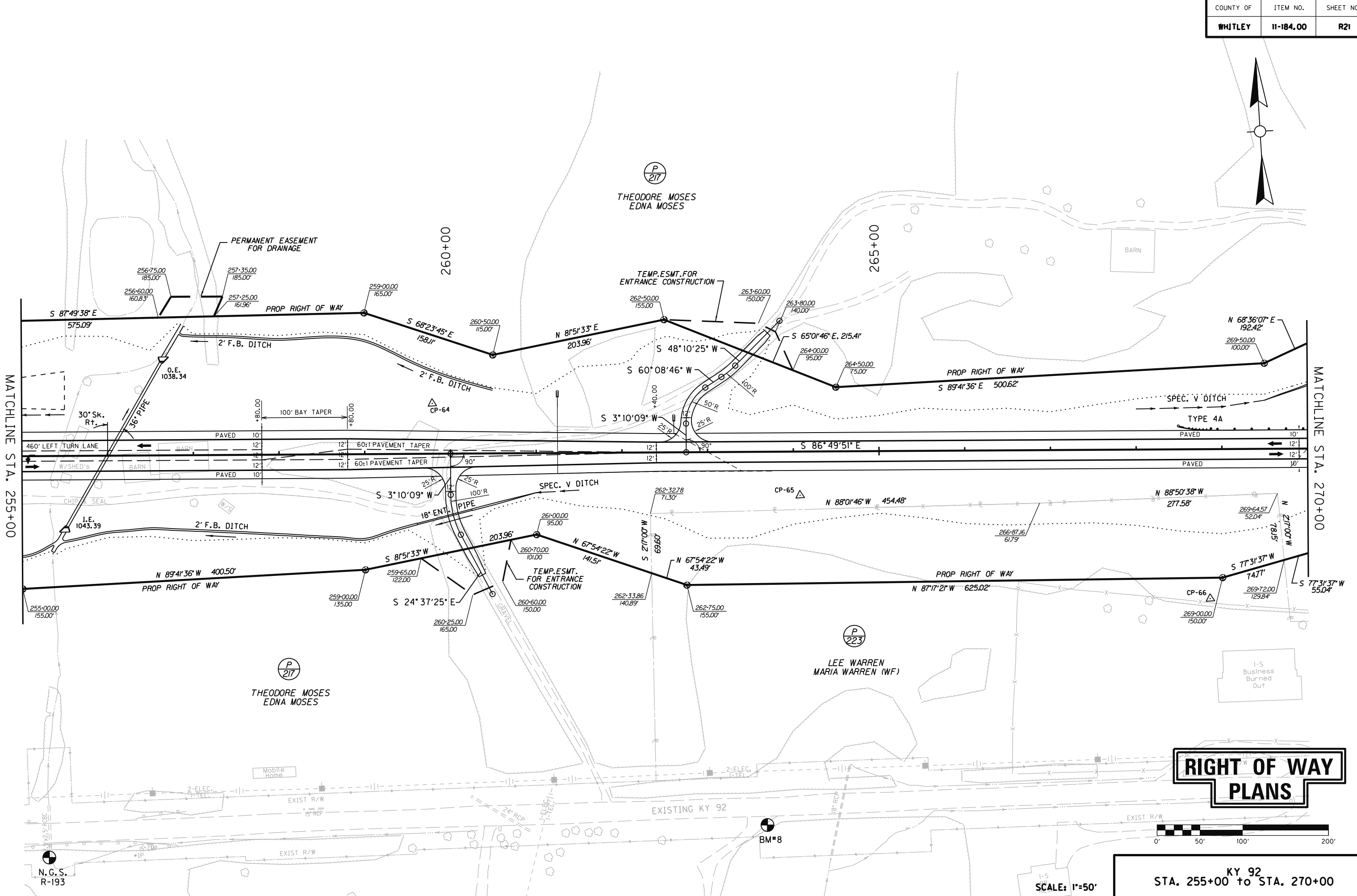

**RIGHT OF WAY
PLANS**

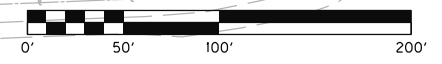

KY 92
 STA. 255+00 to STA. 270+00
 SCALE: 1"=50'

MicroStation v8.11.7.180 E-SHEET NAME: FILE NAME: G:\ENGR\H0185.01\PHASE I\ACAD\PLANS\ROW\25500PR.DGN
 USER: sdcgrry DATE PLOTTED: June 20, 2013

N.G.S. R-193 1951
 SET IN THE TOP OF THE WEST END OF THE SOUTH HDWL OF A 2' CONCRETE BOX CULVERT, 28' SOUTH OF THE C. OF THE HWY, 1' EAST OF THE WEST END OF THE HDWL AND ABOUT 8' BELOW THE HWY. STA. 255+29.17, 468.67' RT. ELEV. 1065.784

BM#8
 3/4" ALUMINUM DISK SET IN THE TOP OF AN 8" POURED CONCRETE CYLINDER 30" IN DEPTH AND IS FLUSH WITH THE GROUND. STA. 263+67.28, 435.73' RT. ELEV. 1101.998

9119 CY OF TRANSVERSE BENCHES

	STORM (YR)	RUNOFF (cfs)	HEADWATER ELEV (FT)
DESIGN	25	38.2	1046.51
CHECK	100	46.6	1047.08

L 1000.00 FT
 SD 1151.38 FT

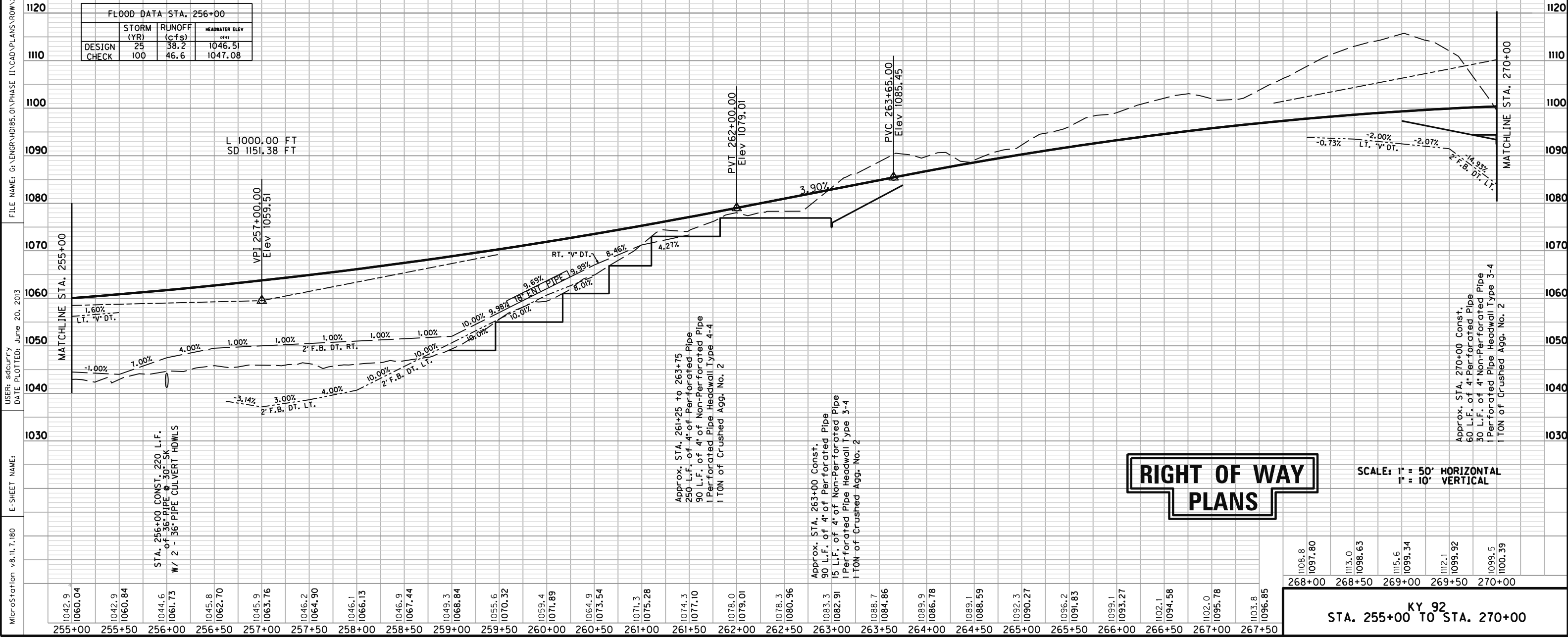

RIGHT OF WAY PLANS

SCALE: 1" = 50' HORIZONTAL
 1" = 10' VERTICAL

1108.8	1113.0	1115.6	1112.1	1099.5
1097.80	1098.63	1099.34	1099.92	1100.39
268+00	268+50	269+00	269+50	270+00

KY 92
 STA. 255+00 TO STA. 270+00

KY 92
P.I. 281+59.19
 $\Delta = 18^\circ 44' 43''$ LT
T = 264.09'
L = 523.47'
R = 1600.00'
E = 21.65'
e = 6.71%
Runoff = 172
Runout = 51
DESIGN SPEED 55 MPH

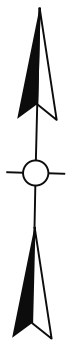

- 1 - S 77° 31' 37" W - 55.04'
- 2 - S 68° 36' 07" W - 43.98'
- 3 - N 80° 18' 40" W - 85.55'

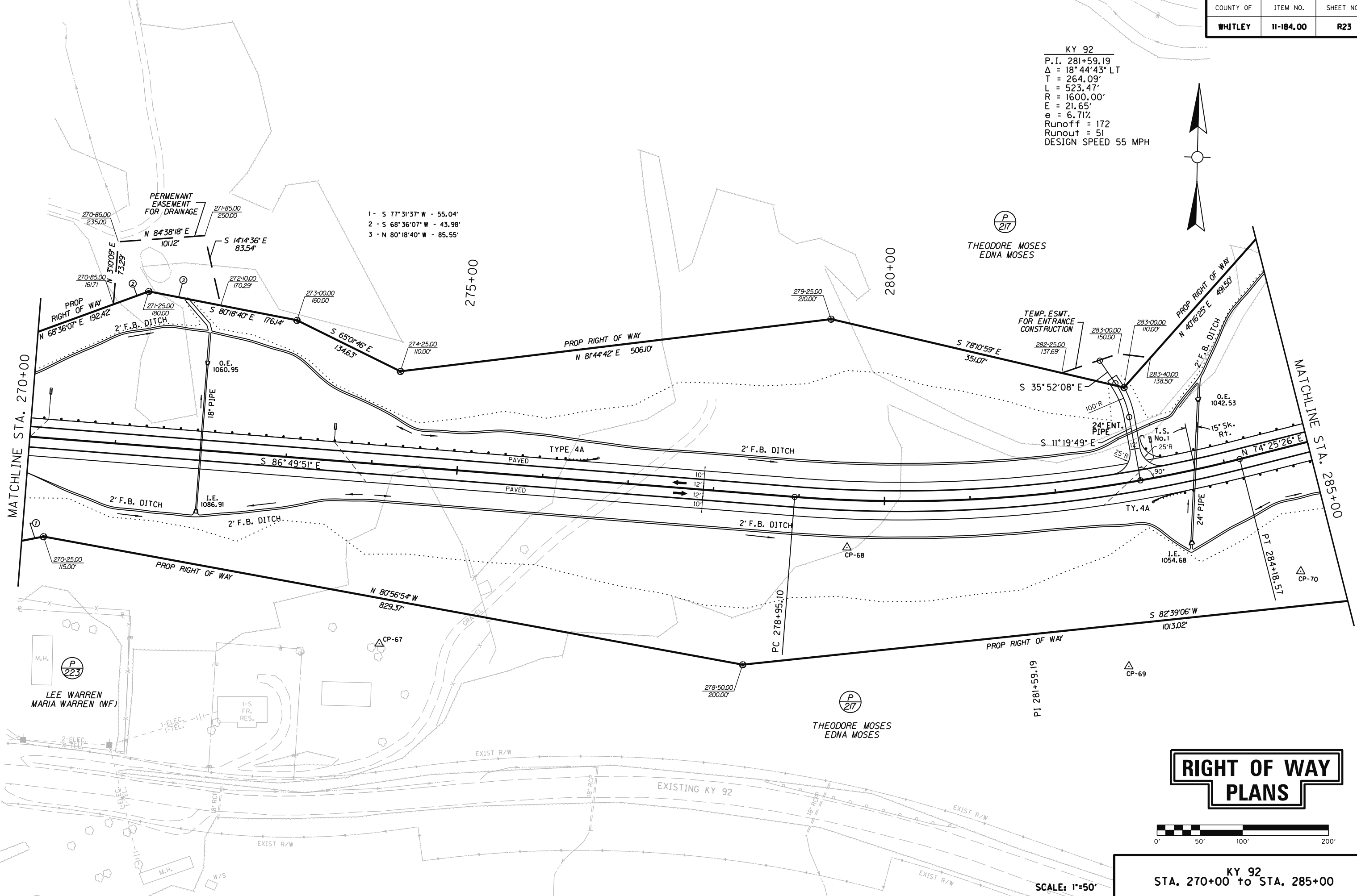

RIGHT OF WAY PLANS

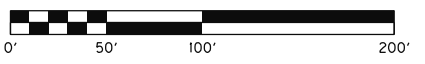

KY 92
STA. 270+00 to STA. 285+00

FILE NAME: G:\ENGR\HD185_01\PHASE II\CAD\PLANS\ROW\27000PL.DGN
 USER: sdcgcty
 DATE PLOTTED: June 20, 2013
 E-SHEET NAME:
 MicroStation v8.11.7.180

	STORM (YR)	RUNOFF (cfs)	HEADWATER ELEV (ft)
DESIGN	25	5.9	1088.22
CHECK	100	7.4	1088.49

	STORM (YR)	RUNOFF (cfs)	HEADWATER ELEV (ft)
DESIGN	25	11.5	1056.44
CHECK	100	13.5	1056.66

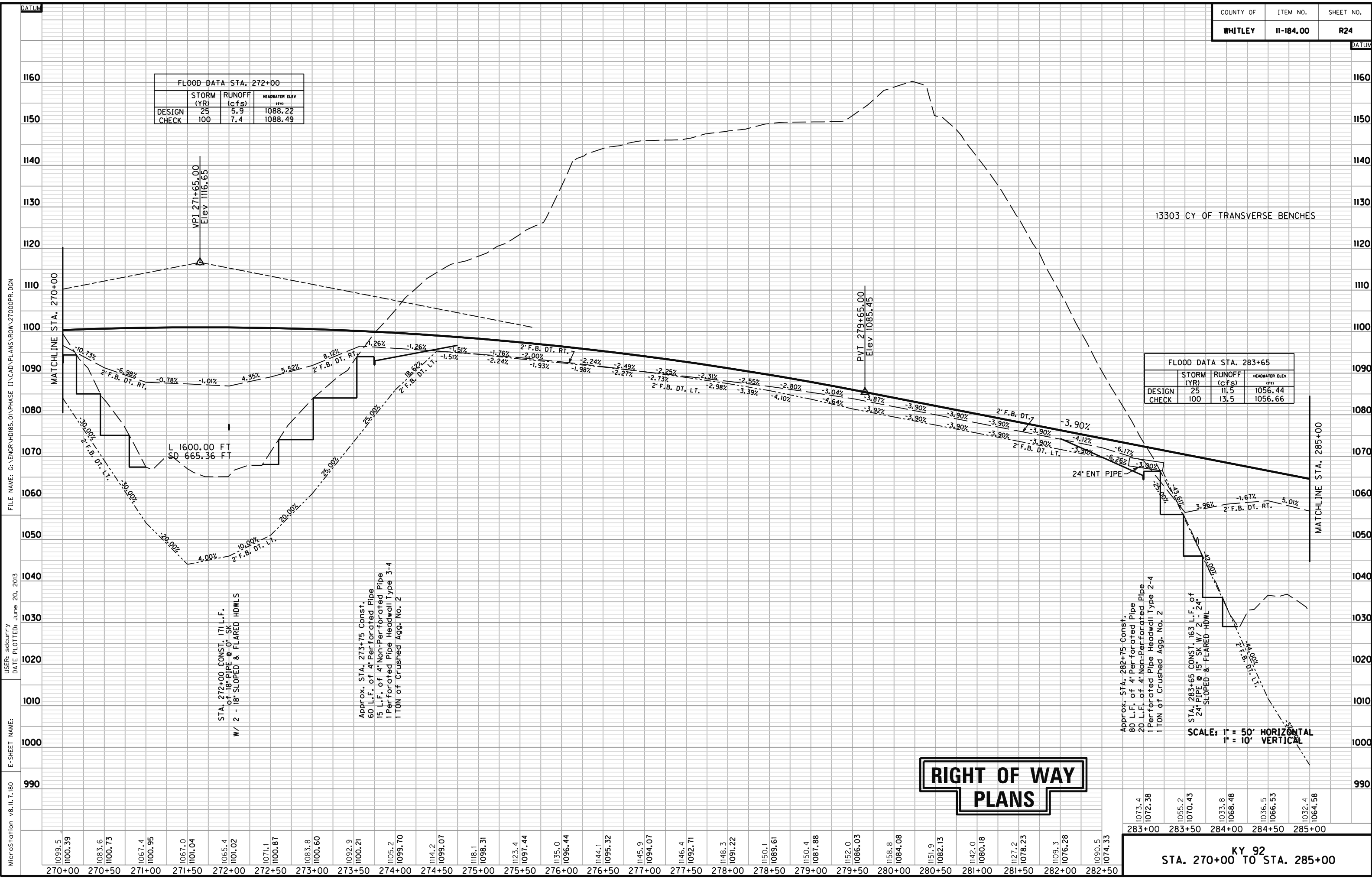

STA. 272+00 CONST. 171 L.F. of 18" PIPE @ 0' SK W/ 2 - 18" SLOPED & FLARED HDWLS

Approx. STA. 273+75 Const. 60 L.F. of 4" Perforated Pipe 15 L.F. of 4" Non-Perforated Pipe 1 Perforated Pipe Headwall Type 3-4 1 TON of Crushed Agg. No. 2

Approx. STA. 282+75 Const. 80 L.F. of 4" Perforated Pipe 20 L.F. of 4" Non-Perforated Pipe 1 Perforated Pipe Headwall Type 2-4 1 TON of Crushed Agg. No. 2

STA. 283+65 CONST. 163 L.F. of 24" PIPE @ 15' SK W/ 2 - 24" SLOPED & FLARED HDWL

SCALE: 1" = 50' HORIZONTAL
1" = 10' VERTICAL

RIGHT OF WAY PLANS

1073.4	1055.2	1033.8	1036.5	1032.4
1072.38	1070.43	1068.48	1066.53	1064.58

KY 92
STA. 270+00 TO STA. 285+00

MicroStation v8.11.7.180 E-SHEET NAME: DATE PLOTTED: June 20, 2013 USER: sdcgury FILE NAME: G:\ENGR\HDB5.0\PHASE II\CAD\PLANS\ROW\27000PR.DGN

BEARING / DISTANCES

- | | |
|---------------------------------|------------------------------|
| 1 - N 65°25'56" E - 25.52' | 13 - N 48°33'11" E - 38.26' |
| 2 - S 18°01'59" W - 95.59' | 14 - N 55°14'15" E - 29.74' |
| 3 - Arc = 249.67', R = 751.20' | 15 - N 47°37'23" E - 29.72' |
| Chd. = S 52°37'18" W - 247.93' | 16 - N 31°22'08" E - 65.39' |
| 4 - S 43°07'23" W - 29.11' | 17 - N 53°52'01" E - 54.94' |
| 5 - N 66°33'45" W - 4.82' | 18 - N 60°05'55" E - 59.73' |
| 6 - N 46°52'37" W - 65.00' | 19 - N 48°00'27" E - 40.30' |
| 7 - N 46°52'37" W - 65.00' | 20 - N 17°29'04" E - 49.15' |
| 8 - S 46°52'37" E - 15.00' | 21 - S 80°17'27" W - 152.95' |
| 9 - N 43°07'23" E - 100.00' | |
| 10 - N 46°52'37" W - 15.00' | |
| 11 - N 43°07'23" E - 59.04' | |
| 12 - Arc = 225.86', R = 681.20' | |
| Chd. = N 52°37'18" E - 224.83' | |

DIVERSION #2

P.I. 96+49.89
 $\Delta = 25^\circ 58' 43" \text{ LT}$
 $T = 115.34'$
 $L = 226.71'$
 $R = 500.00'$
 $E = 13.13'$
 $e = 5.60\%$
 Runoff = See Sections
 Runout = See Sections
 DESIGN SPEED 35 MPH

DIVERSION #1

P.I. 100+34.65
 $\Delta = 26^\circ 32' 22" \text{ RT}$
 $T = 212.25'$
 $L = 416.88'$
 $R = 900.00'$
 $E = 24.69'$
 $e = 4.40\%$
 Runoff = See Sections
 Runout = See Sections
 DESIGN SPEED 35 MPH

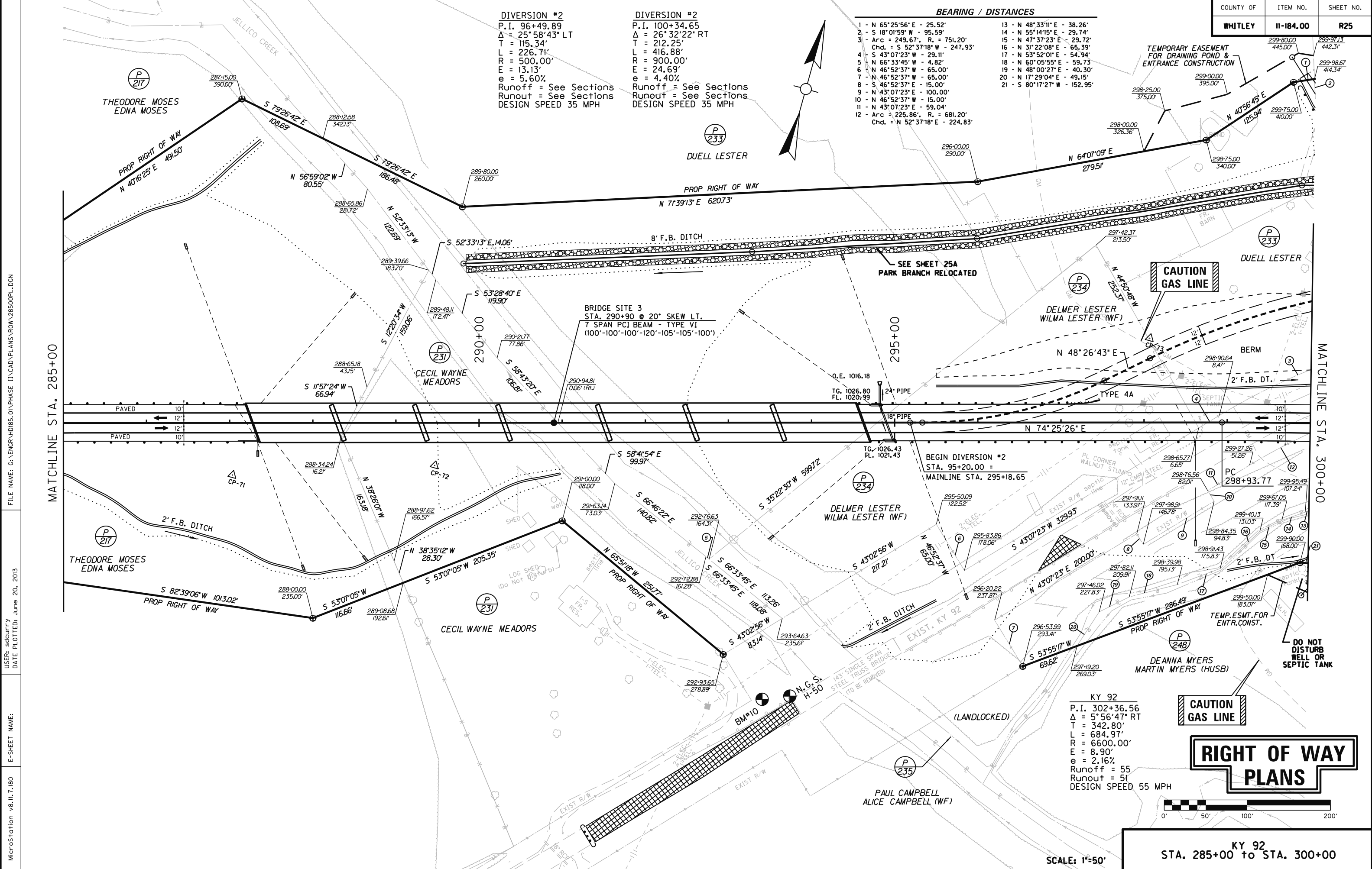
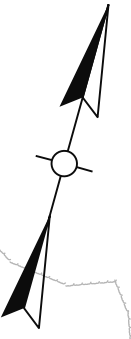

RIGHT OF WAY PLANS

KY 92
 P.I. 302+36.56
 $\Delta = 5^\circ 56' 47" \text{ RT}$
 $T = 342.80'$
 $L = 684.97'$
 $R = 6600.00'$
 $E = 8.90'$
 $e = 2.16\%$
 Runoff = 55
 Runout = 51
 DESIGN SPEED 55 MPH

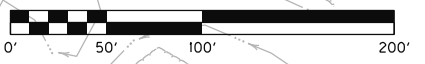

SCALE: 1"=50'

KY 92
 STA. 285+00 to STA. 300+00

FILE NAME: G:\ENGR\HDIB5_01\PHASE 1\ACAD\PLANS\ROW\28500PL.DGN

USER: sdcgcty
 DATE PLOTTED: June 20, 2013

E-SHEET NAME:

MicroStation v8.11.7.180

MATCHLINE STA. 285+00

MATCHLINE STA. 300+00

BEARING / DISTANCES

- | | |
|---|--|
| 1 - Arc = 55.39', R. = 816.20'
Chd. = S 64°03'52" W - 55.38' | 24 - S 23°04'56" W - 117.59'
Chd. = S 64°03'52" W - 55.38' |
| 2 - Arc = 27°52'47" E - 65.00' | 40 - Arc = 167.01', R. = 331.97'
Chd. = S 57°05'49" W - 165.25' |
| 3 - Arc = 249.07', R. = 751.20'
Chd. = S 52°37'18" W - 247.93' | 41 - S 71°30'32" W - 182.84'
Chd. = S 52°37'18" W - 247.93' |
| 4 - Arc = 225.86', R. = 681.20'
Chd. = N 52°37'18" E, 224.83' | 42 - N 18°29'28" W - 50.00'
Chd. = N 52°37'18" E, 224.83' |
| 5 - S 27°52'47" E - 65.00' | 43 - S 71°30'32" W - 82.64'
Chd. = N 52°37'18" E, 224.83' |
| 6 - Arc = 20.60', R. = 616.20'
Chd. = N 63°04'40" E - 20.60' | 44 - Arc = 78.35', R. = 816.20'
Chd. = S 68°45'31" W - 78.32' |
| 7 - N 18°25'41" E - 17.79' | |
| 8 - N 45°40'56" E - 24.38' | |
| 9 - N 56°07'58" E - 28.86' | |
| 13 - Arc = 31.23', R. = 616.20'
Chd. = N 70°03'25" E - 31.23' | |
| 14 - N 71°30'32" E - 82.64' | |
| 15 - N 18°29'28" W - 30.00' | |
| 16 - N 71°30'32" E - 182.84' | |

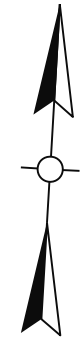

FILE NAME: G:\ENGR\H0185_01\PHASE 1\ACAD\PLANS\ROW\28500APL.DGN
 USER: H0150N
 DATE PLOTTED: June 20, 2013
 MicroStation v8.11.7.180 E-SHEET NAME:

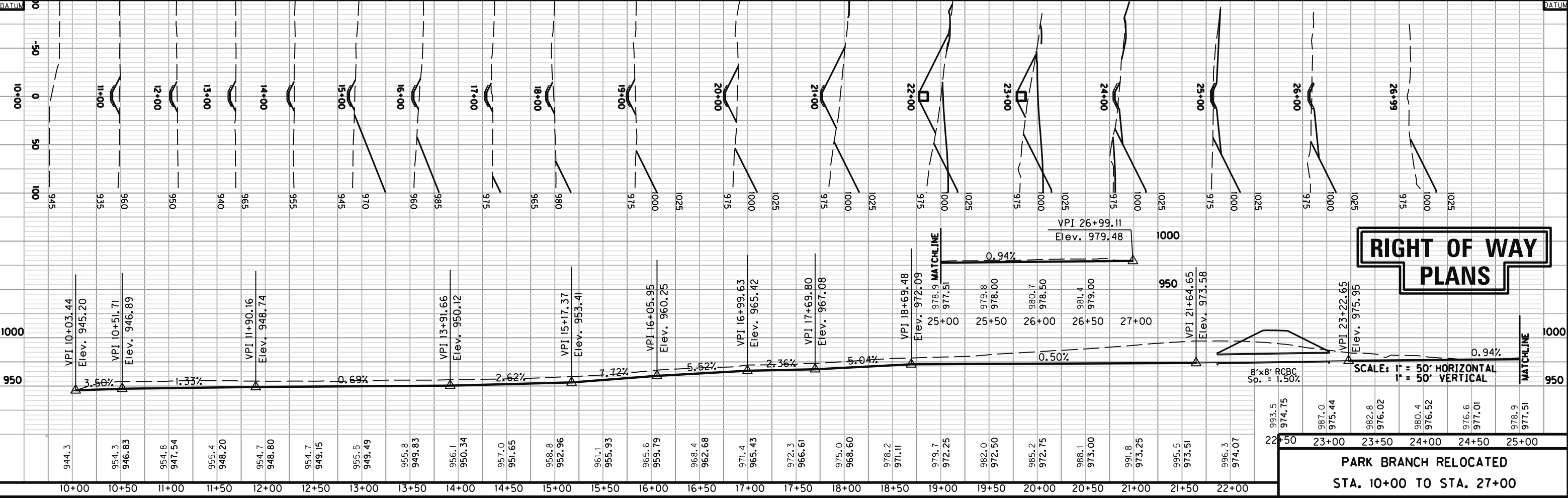
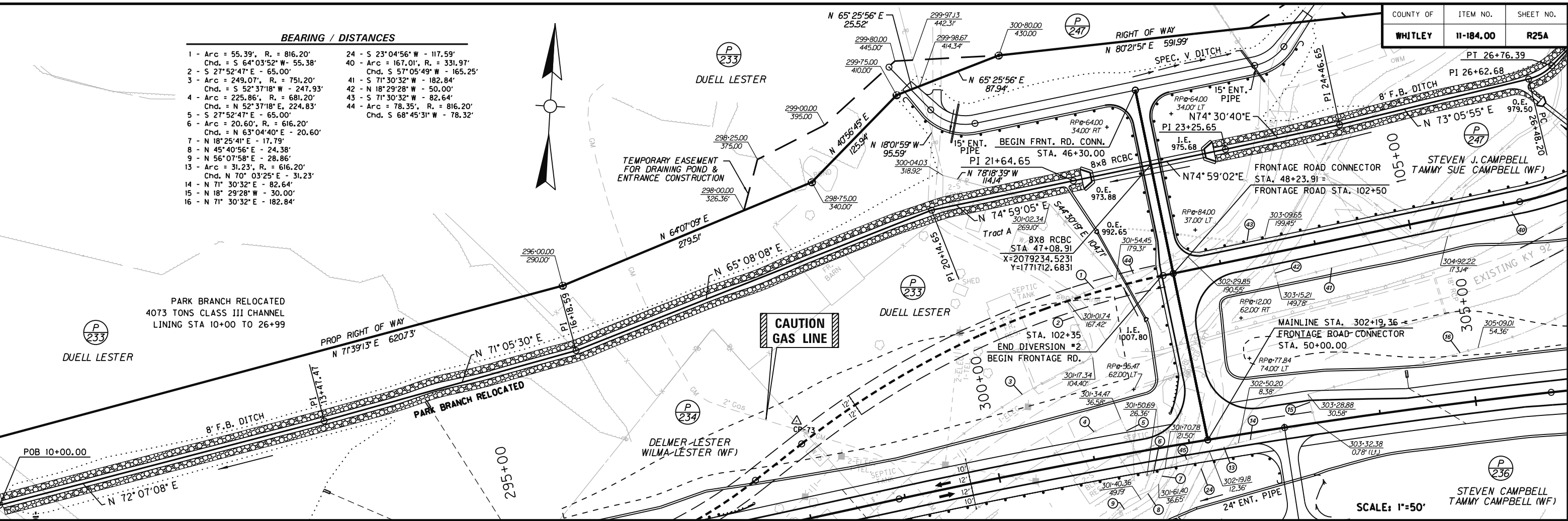

RIGHT OF WAY PLANS

SCALE: 1" = 50' HORIZONTAL
1" = 50' VERTICAL

**PARK BRANCH RELOCATED
STA. 10+00 TO STA. 27+00**

FLOOD DATA				
	STORM (YR)	RUNOFF (cfs)	HEADWATER ELEV. (ft)	VELOCITY (fps)
DESIGN	50	13,800	959.39	7.4
CHECK	100	14,400	959.67	7.6

N.G.S. H-50 1935
 SET IN THE TOP OF THE NORTHWEST END OF THE SOUTHWEST ABUTMENT OF THE BRIDGE OVER JELICO CREEK, 16' NORTHWEST OF THE C OF THE HIGHWAY AND ABOUT 1.5' BELOW THE GROUND.
 STA. 293+73.77, 329.17' RT.
 ELEV. 974.213

BM#10
 3/4" ALUMINUM DISK SET IN THE TOP OF AN 8" POURED CONCRETE CYLINDER 30" IN DEPTH AND IS FLUSH WITH THE GROUND.
 STA. 293+40.36, 332.96' RT.
 ELEV. 985.620

BRIDGE SITE 3
 STA. 290+90 @ 20° SKEW LT.
 7 SPAN PCI BEAM - TYPE VI
 (100-100-100-120-105-105-100)

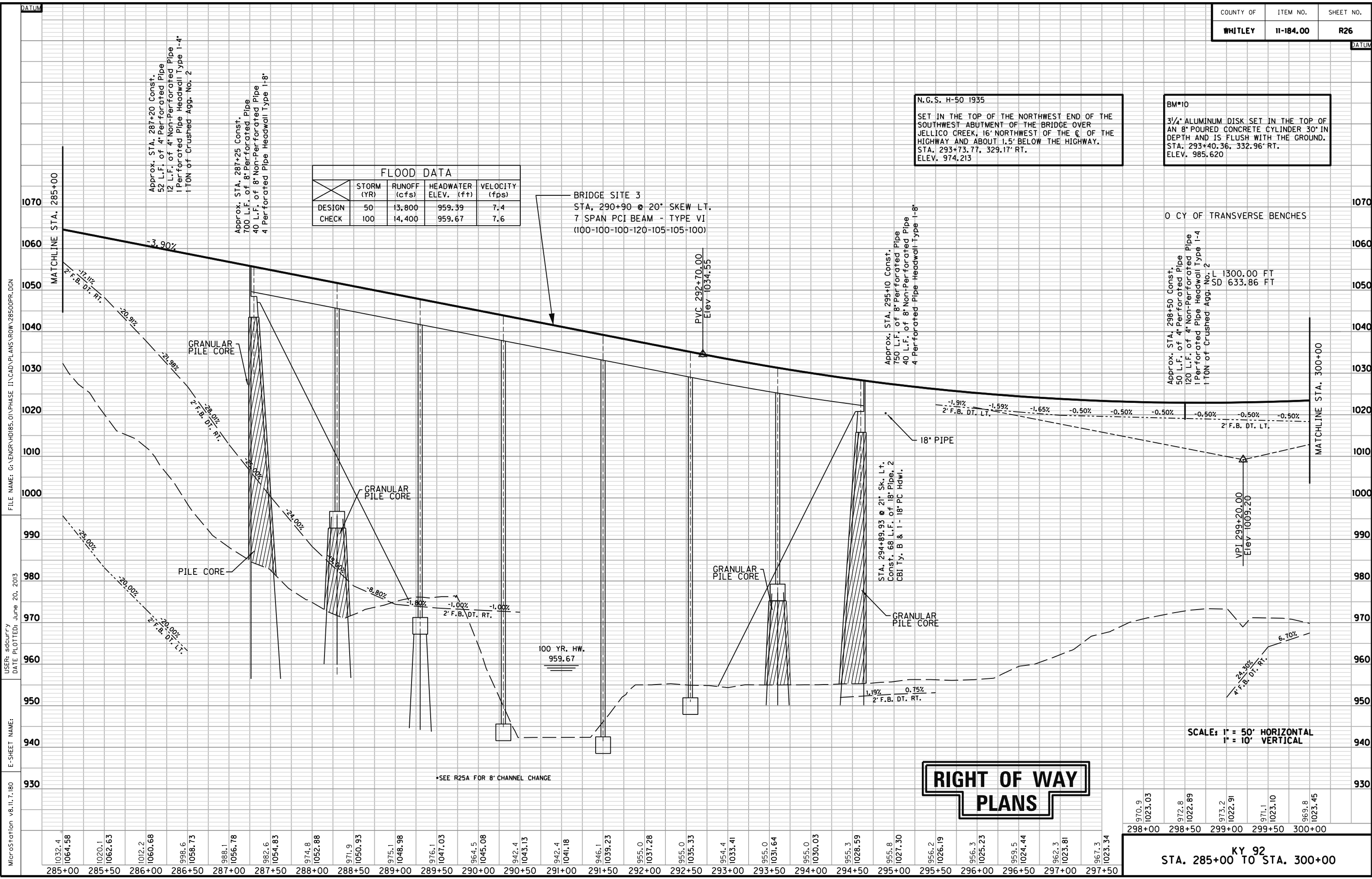

MicroStation v8.11.7.180 E-SHEET NAME: G:\ENGR\H0185.01\PHASE I\ACAD\PLANS\ROW\28500PR.DGN
 USER: sdcgury DATE PLOTTED: June 20, 2013

1032.4	1020.1	1012.2	998.6	988.1	982.6	974.8	971.9	975.1	976.1	964.5	942.4	942.4	946.1	955.0	955.0	954.4	955.0	955.3	955.8	956.2	956.3	959.5	962.3	967.3	
1064.58	1062.63	1060.68	1058.73	1056.78	1054.83	1052.88	1050.93	1048.98	1047.03	1045.08	1043.13	1041.18	1039.23	1037.28	1035.33	1033.41	1031.64	1030.03	1028.59	1027.30	1026.19	1025.23	1024.44	1023.81	1023.34
285+00	285+50	286+00	286+50	287+00	287+50	288+00	288+50	289+00	289+50	290+00	290+50	291+00	291+50	292+00	292+50	293+00	293+50	294+00	294+50	295+00	295+50	296+00	296+50	297+00	297+50

970.9	972.8	973.2	971.1	969.8
1023.03	1022.89	1022.91	1023.10	1023.45
298+00	298+50	299+00	299+50	300+00

KY 92
 STA. 285+00 TO STA. 300+00

MicroStation v8.11.7.180 E-SHEET NAME: DATE PLOTTED: June 20, 2013 USER: sdcgury COUNTY OF WHITLEY ITEM NO. 11-184.00 SHEET NO. R27

PROPERTY OWNERS

235 - PAUL & ALICE CAMPBELL (WF.)
 238 - VERNON & JEWELL D. STEPHENS (WF)
 248 - DEANNA & MARTIN MYERS (HUSB.)

BEARING / DISTANCES

- | | | |
|---|--|--|
| 1 - Arc = 55.39', R. = 816.20'
Chd. = S 64°03'52" W - 55.38' | 17 - Arc = 219.55', R. = 451.97'
Chd. = N 57°35'35" E - 217.40' | 34 - Arc = 11.19', R. = 527.47'
Chd. = S 30°17'49" W - 11.19' |
| 2 - S 27°52'47" E - 65.00' | 18 - S 80°17'27" W - 21.49' | 35 - S 29°41'21" W - 98.13' |
| 3 - Arc = 249.07', R. = 751.20'
Chd. = S 52°37'18" W - 247.93' | 19 - S 62°28'48" E - 77.62' | 36 - Arc = 31.84', R. = 331.97'
Chd. = S 32°26'13" W - 31.83' |
| 4 - Arc = 225.86', R. = 681.20'
Chd. = N 52°37'18" E, 224.83' | 20 - N 87°31'12" E - 67.00' | 37 - N 54°48'55" W - 50.00' |
| 5 - S 27°52'47" E - 65.00' | 21 - N 11°31'12" E - 59.43' | 38 - Arc = 36.91', R. = 281.97'
Chd. = S 38°56'05" W - 36.88' |
| 6 - Arc = 20.60', R. = 616.20'
Chd. = N 63°04'40" E - 20.60' | 22 - S 80°17'27" W - 50.91' | 39 - S 47°18'55" E - 50.00' |
| 7 - N 18°25'41" E - 17.79' | 23 - S 11°23'26" E - 72.32' | 40 - Arc = 167.01', R. = 331.97'
Chd. = S 57°05'49" W - 165.25' |
| 8 - N 45°40'56" E - 24.38' | 24 - S 23°04'56" W - 117.59' | 41 - S 71°30'32" W - 182.84' |
| 9 - N 56°07'58" E - 28.86' | 25 - Arc = 110.34', R. = 451.97'
Chd. = N 36°40'59" E - 110.07' | 42 - N 18°29'28" W - 50.00' |
| 10 - N 40°03'25" E - 16.36' | 26 - N 29°41'21" E - 38.37' | 43 - S 71°30'32" W - 82.64' |
| 11 - N 58°53'30" E - 71.94' | 27 - N 60°18'39" W - 35.00' | 44 - Arc = 78.35', R. = 816.20'
Chd. = S 68°45'31" W - 78.32' |
| 12 - N 48°33'11" E - 38.26' | 28 - N 29°41'21" E - 59.77' | 45 - Arc = 49.14', R. = 616.20'
Chd. = N 66°19'12" E - 49.13' |
| 13 - Arc = 31.23', R. = 616.20'
Chd. = N 70°03'25" E - 31.23' | 29 - Arc = 8.35', R. = 442.47'
Chd. = N 30°13'48" E - 8.35' | 46 - S 80°17'27" W - 152.95' |
| 14 - N 71°30'32" E - 82.64' | 30 - N 8°54'30" W - 17.32' | 47 - S 80°17'27" W - 149.79' |
| 15 - N 18°29'28" W - 30.00' | 31 - S 78°14'57" W - 9.50' | |
| 16 - N 71°30'32" E - 182.84' | 32 - N 21°58'03" W - 79.17' | |
| | 33 - N 65°25'56" E - 87.94' | |

COUNTY OF	ITEM NO.	SHEET NO.
WHITLEY	11-184.00	R27

KY 92
 P.I. 302+36.56
 $\Delta = 5^\circ 56' 47''$ RT
 T = 342.80'
 L = 684.97'
 R = 6600.00'
 e = 8.90'
 e = 2.16%
 Runoff = 55
 Runout = 51
 DESIGN SPEED 55 MPH

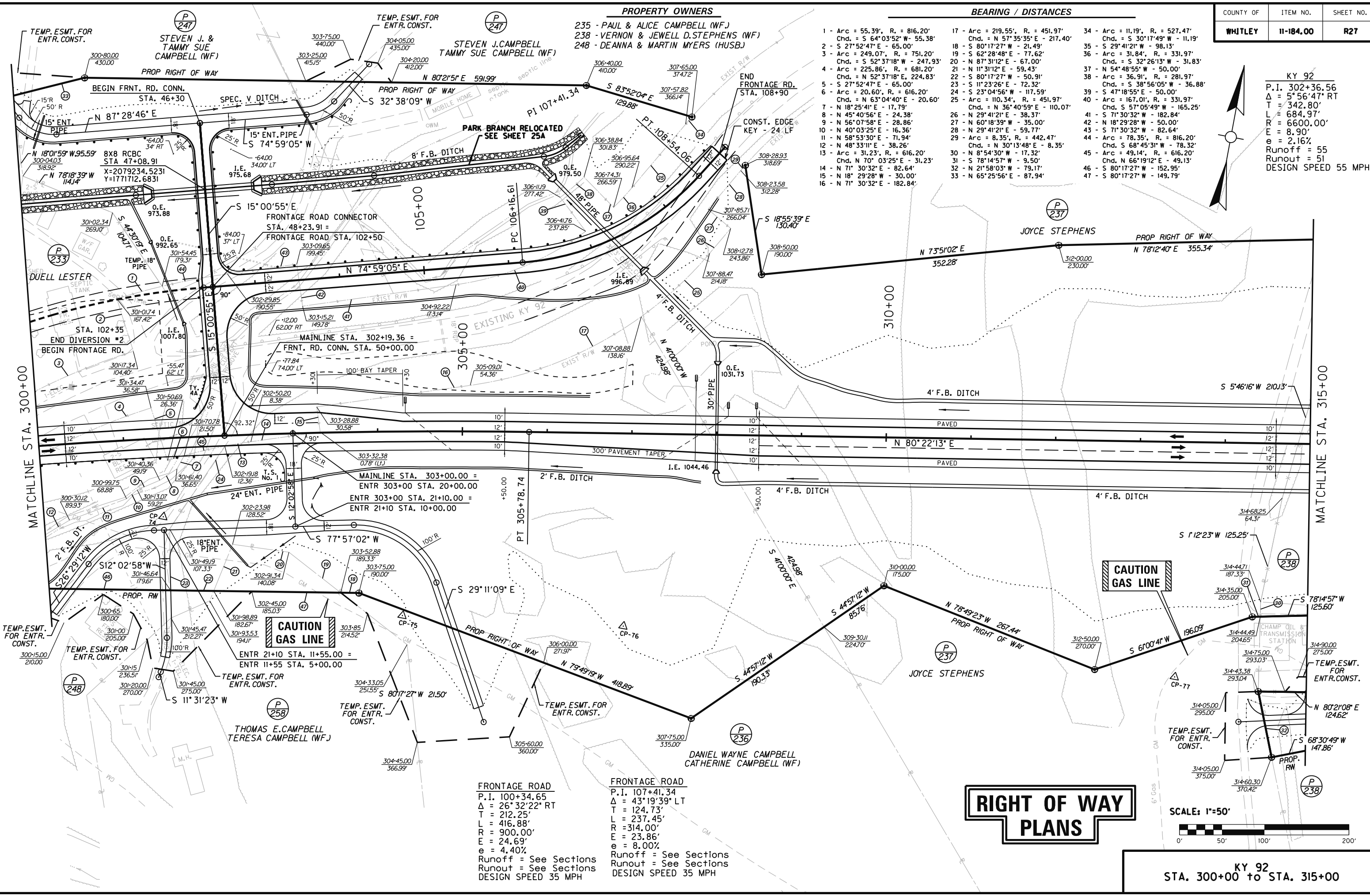

FRONTAGE ROAD
 P.I. 100+34.65
 $\Delta = 26^\circ 32' 22''$ RT
 T = 212.25'
 L = 416.88'
 R = 900.00'
 e = 24.69'
 e = 4.40%
 Runoff = See Sections
 Runout = See Sections
 DESIGN SPEED 35 MPH

FRONTAGE ROAD
 P.I. 107+41.34
 $\Delta = 43^\circ 19' 39''$ LT
 T = 124.73'
 L = 237.45'
 R = 314.00'
 e = 23.86'
 e = 8.00%
 Runoff = See Sections
 Runout = See Sections
 DESIGN SPEED 35 MPH

RIGHT OF WAY PLANS

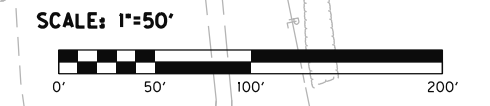

KY 92
 STA. 300+00 to STA. 315+00

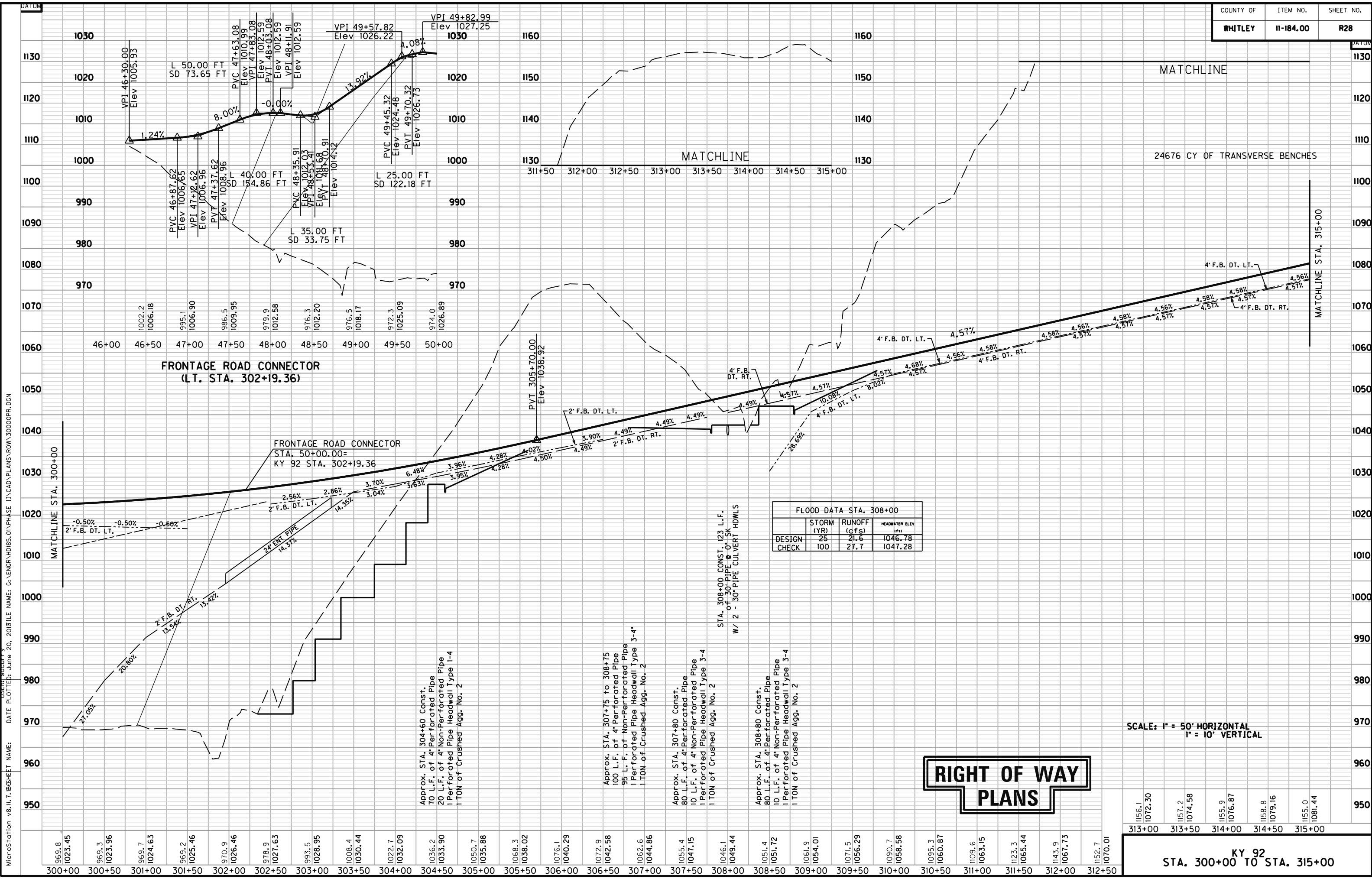

MicroStation v8.11.7.063 SHEET NAME: G:\ENGR\10185.01\PHASE 11\CAD\PLANS\ROW\3000PR.DGN
 DATE PLOTTED: June 20, 2018 FILE NAME: G:\ENGR\10185.01\PHASE 11\CAD\PLANS\ROW\3000PR.DGN

SCALE: 1" = 50' HORIZONTAL
1" = 10' VERTICAL

KY 92
STA. 300+00 TO STA. 315+00

FILE NAME: G:\ENGR\H185.01\PHASE II\CAD\PLANS\ROW\30000APR.DGN
 USER: sdcvcty
 DATE PLOTTED: June 20, 2013
 E-SHEET NAME: MicroStation v8.11.7.180

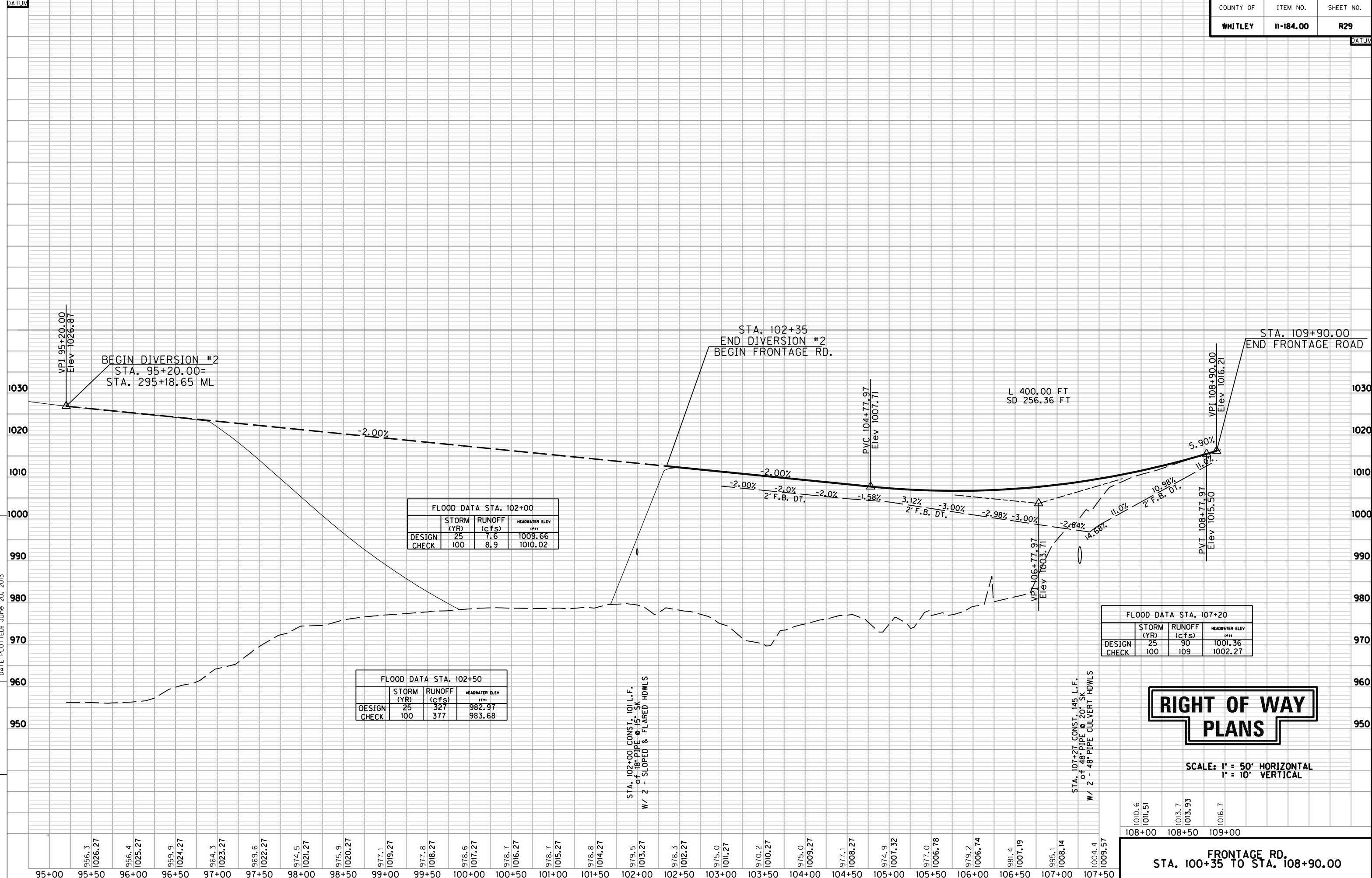

FLOOD DATA STA. 102+00

	STORM (YR)	RUNOFF (cfs)	HEADWATER ELEV (ft)
DESIGN	25	7.6	1009.66
CHECK	100	8.9	1010.02

FLOOD DATA STA. 102+50

	STORM (YR)	RUNOFF (cfs)	HEADWATER ELEV (ft)
DESIGN	25	327	982.97
CHECK	100	377	983.68

FLOOD DATA STA. 107+20

	STORM (YR)	RUNOFF (cfs)	HEADWATER ELEV (ft)
DESIGN	25	90	1001.36
CHECK	100	109	1002.27

STA. 102+00 CONST. 101 L.F. of 18" PIPE @ 15' SK W/ 2 - SLOPED & FLARED HDWLS

STA. 107+27 CONST. 145 L.F. of 48" PIPE @ 20' SK W/ 2 - 48" PIPE CULVERT HDWLS

RIGHT OF WAY PLANS

SCALE: 1" = 50' HORIZONTAL
1" = 10' VERTICAL

1010.6
1011.51
1013.7
1013.95
1016.7
108+00 108+50 109+00

FRONTAGE RD.
STA. 100+35 TO STA. 108+90.00

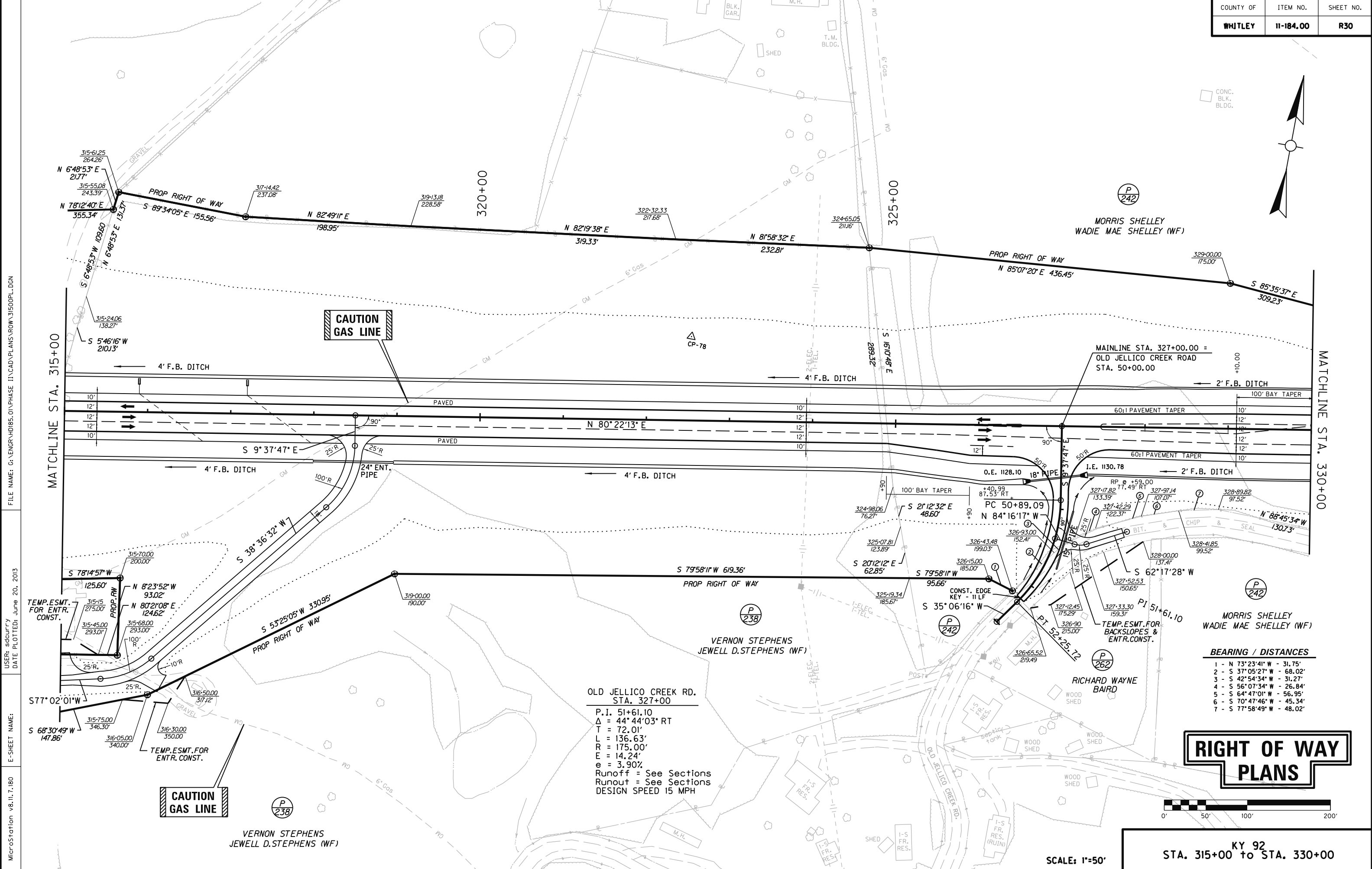
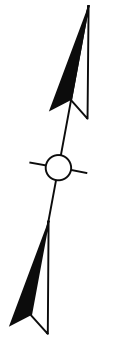

FILE NAME: G:\ENGR\HDIB5_01\PHASE II\CAD\PLANS\ROW\31500PL.DGN
 USER: sdcgtry
 DATE PLOTTED: June 20, 2013
 E-SHEET NAME:
 MicroStation v8.11.7.180

OLD JELICO CREEK RD.
 STA. 327+00

P.I. 51+61.10
 $\Delta = 44^\circ 44' 03''$ RT
 T = 72.01'
 L = 136.63'
 R = 175.00'
 E = 14.24'
 e = 3.90%
 Runoff = See Sections
 Runout = See Sections
 DESIGN SPEED 15 MPH

BEARING / DISTANCES

- 1 - N 73° 23' 41" W - 31.75'
- 2 - S 37° 05' 27" W - 68.02'
- 3 - S 42° 54' 34" W - 31.27'
- 4 - S 56° 07' 34" W - 26.84'
- 5 - S 64° 47' 01" W - 56.95'
- 6 - S 70° 47' 46" W - 45.34'
- 7 - S 77° 58' 49" W - 48.02'

**RIGHT OF WAY
PLANS**

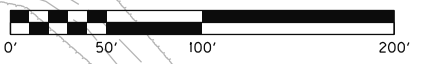

SCALE: 1"=50'

KY 92
 STA. 315+00 to STA. 330+00

MicroStation v8.11.7.180 E-SHEET NAME: USER: sdcgcty DATE PLOTTED: June 20, 2013 FILE NAME: G:\ENGR\H0185.0\PHASE II\CAD\PLANS\ROW\31500PR.DGN

COUNTY OF	ITEM NO.	SHEET NO.
WHITLEY	11-184.00	R31

DESIGN CHECK	STORM (YR)	RUNOFF (cfs)	HEADWATER ELEV (ft)
	25	4.2	1131.89
	100	5.2	1132.06

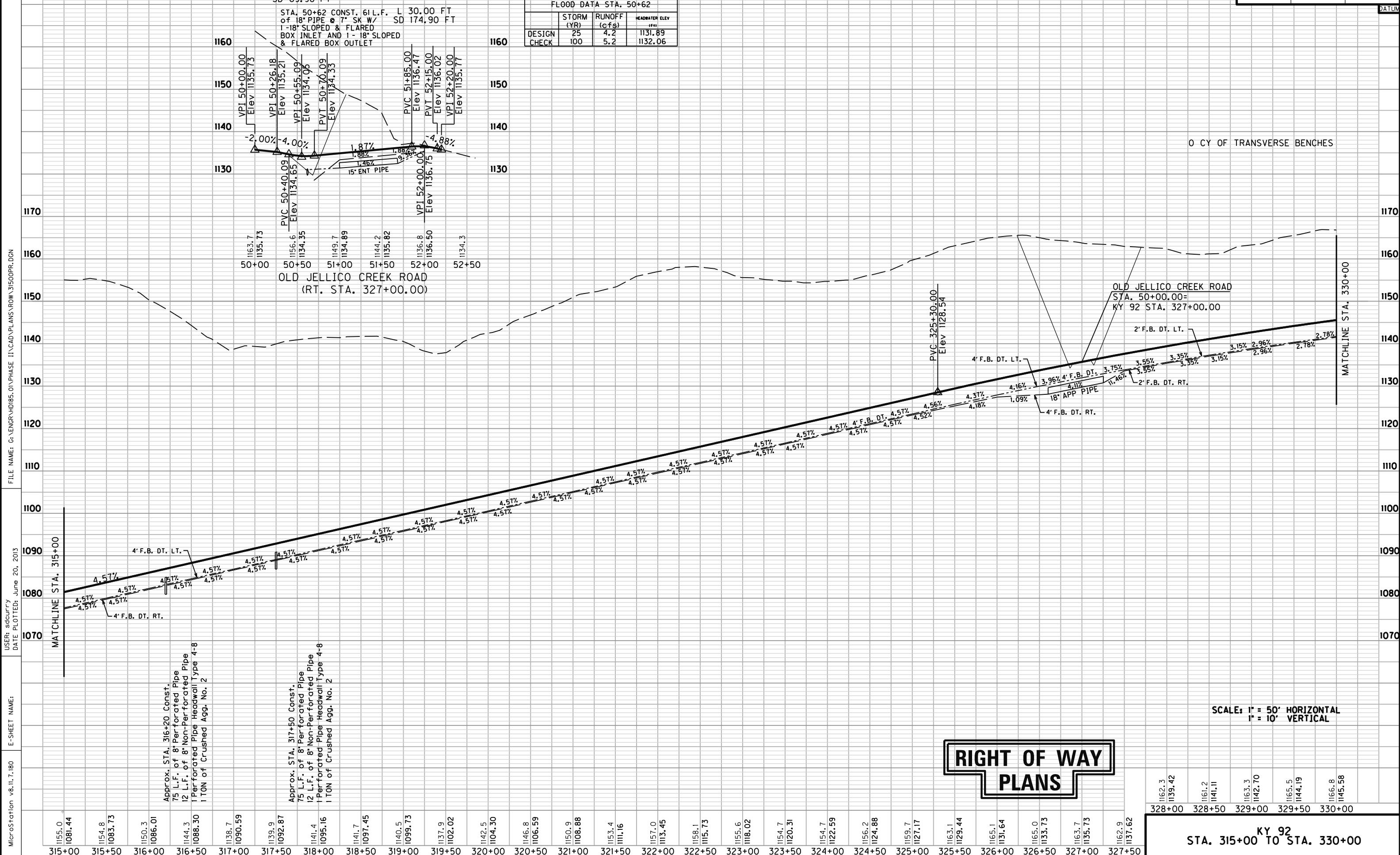

Approx. STA. 316+20 Const.
 75 L.F. of 8' Perforated Pipe
 12 L.F. of 8' Non-Perforated Pipe
 1 Perforated Pipe Headwall Type 4-8
 1 TON of Crushed Agg. No. 2

Approx. STA. 317+50 Const.
 75 L.F. of 8' Perforated Pipe
 12 L.F. of 8' Non-Perforated Pipe
 1 Perforated Pipe Headwall Type 4-8
 1 TON of Crushed Agg. No. 2

RIGHT OF WAY PLANS

SCALE: 1" = 50' HORIZONTAL
 1" = 10' VERTICAL

1162.3	1139.42	1161.2	1141.11	1163.3	1142.70	1165.5	1144.19	1166.8	1145.58
328+00	328+50	329+00	329+50	330+00					

STA. 315+00 TO STA. 330+00
 KY 92

KY 92 CONNECTOR NO. 2

P.I. 47+92.71
 $\Delta = 61^{\circ}05'29''$ RT
 T = 162.28'
 L = 293.22'
 R = 275.00'
 E = 44.31'
 e = 6.10%
 Runoff = See Sections
 Runout = See Sections
 DESIGN SPEED 20 MPH

KY 92

P.I. 343+25.05
 $\Delta = 11^{\circ}22'46''$ LT
 T = 298.90'
 L = 595.83'
 R = 3000.00'
 E = 14.85'
 e = 4.29%
 Runoff = 164
 Runout = 77
 DESIGN SPEED 55 MPH

BEARING / DISTANCES

- | | |
|----------------------------------|-----------------------------------|
| 1 - N 50°38'20" E - 23.13' | 19 - N 54°15'05" E - 146.68' |
| 2 - N 40°50'53" E - 77.57' | 20 - N 45°16'30" E - 39.67' |
| 3 - N 35°24'14" E - 109.97' | 21 - Arc = 30.36', R. = 2057.40' |
| 4 - N 71°55'49" W - 20.70' | Chd. = S 77°23'49" E - 30.36' |
| 5 - Arc = 196.91', R. = 2057.40' | 22 - S 12°10'50" W - 15.00' |
| Chd. = S 72°20'19" E - 196.83' | 23 - Arc = 76.85', R. = 2072.40' |
| 6 - S 12°30'19" E - 31.08' | Chd. = S 78°52'55" E - 76.85' |
| 7 - S 54°28'20" W - 130.98' | 24 - N 10°03'21" E - 15.00' |
| 8 - S 48°30'54" W - 30.42' | 25 - Arc = 163.01', R. = 2057.40' |
| 9 - S 40°03'42" W - 41.68' | Chd. = S 82°12'51" E - 162.97' |
| 10 - S 40°50'53" W - 73.57' | 26 - S 10°21'11" W - 113.33' |
| 11 - S 50°38'20" W - 54.11' | 27 - Arc = 181.10', R. = 2057.40' |
| 12 - S 61°58'22" W - 58.61' | Chd. = S 87°00'21" E - 181.04' |
| 13 - S 74°45'32" W - 68.16' | 28 - Arc = 204.37', R. = 2057.40' |
| 14 - S 85°20'53" W - 46.14' | Chd. = N 87°37'37" E - 204.28' |
| 15 - N 88°45'34" W - 130.73' | 29 - N 73°26'13" E - 196.90' |
| 16 - N 35°24'14" E - 5.98' | 30 - Arc = 291.20', R. = 1987.40' |
| 17 - N 40°03'42" E - 38.24' | Chd. = S 87°21'26" W - 290.94' |
| 18 - N 48°30'54" E - 26.53' | 31 - S 74°39'35" W - 97.93' |

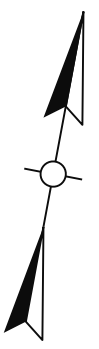

CAUTION GAS LINE

CAUTION GAS LINE

CAUTION GAS LINE

RIGHT OF WAY PLANS

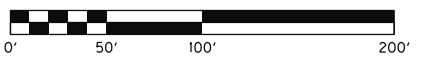

SCALE: 1"=50'

KY 92
 STA. 330+00 to STA. 345+00

FILE NAME: G:\ENGR\HDIB5\01PHASE 1\ACAD\PLANS\ROW\33000PL.DGN
 USER: sdcgury DATE PLOTTED: June 20, 2013
 MicroStation v8.11.7.180 E-SHEET NAME:

MATCHLINE STA. 330+00

MATCHLINE STA. 345+00

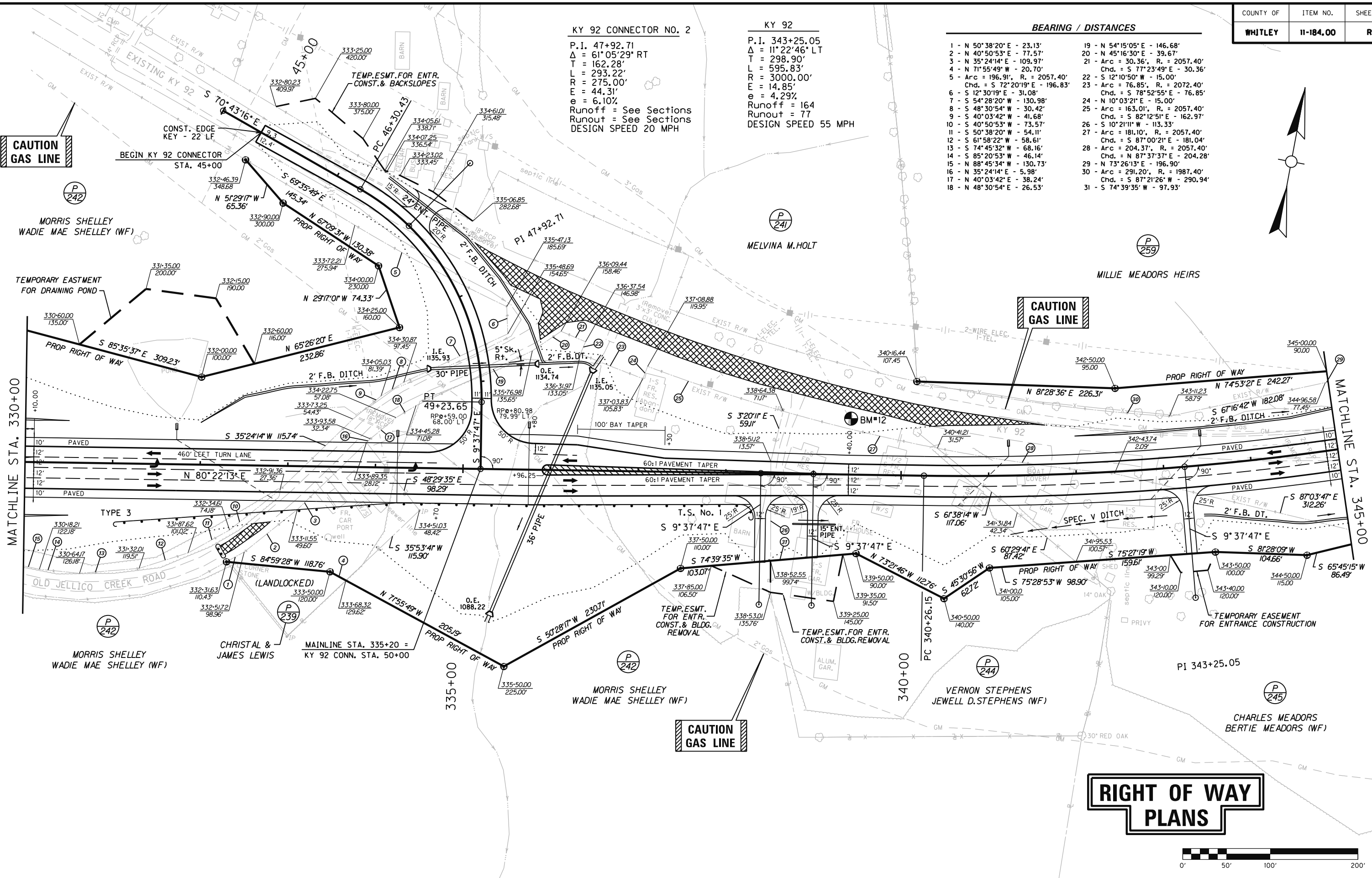

MORRIS SHELLEY
 WADIE MAE SHELLEY (WF)

MELVINA M. HOLT

MILLIE MEADORS HEIRS

MORRIS SHELLEY
 WADIE MAE SHELLEY (WF)

CHRISTAL &
 JAMES LEWIS

MORRIS SHELLEY
 WADIE MAE SHELLEY (WF)

VERNON STEPHENS
 JEWELL D. STEPHENS (WF)

CHARLES MEADORS
 BERTIE MEADORS (WF)

MicroStation v8.11.7.180 E-SHEET NAME: USER: sdcgury DATE PLOTTED: June 20, 2013 FILE NAME: G:\ENGR\H085.01\PHASE I\ACAD\PLANS\ROW\3300OPR.DGN

COUNTY OF	ITEM NO.	SHEET NO.
WHITLEY	11-184.00	R33

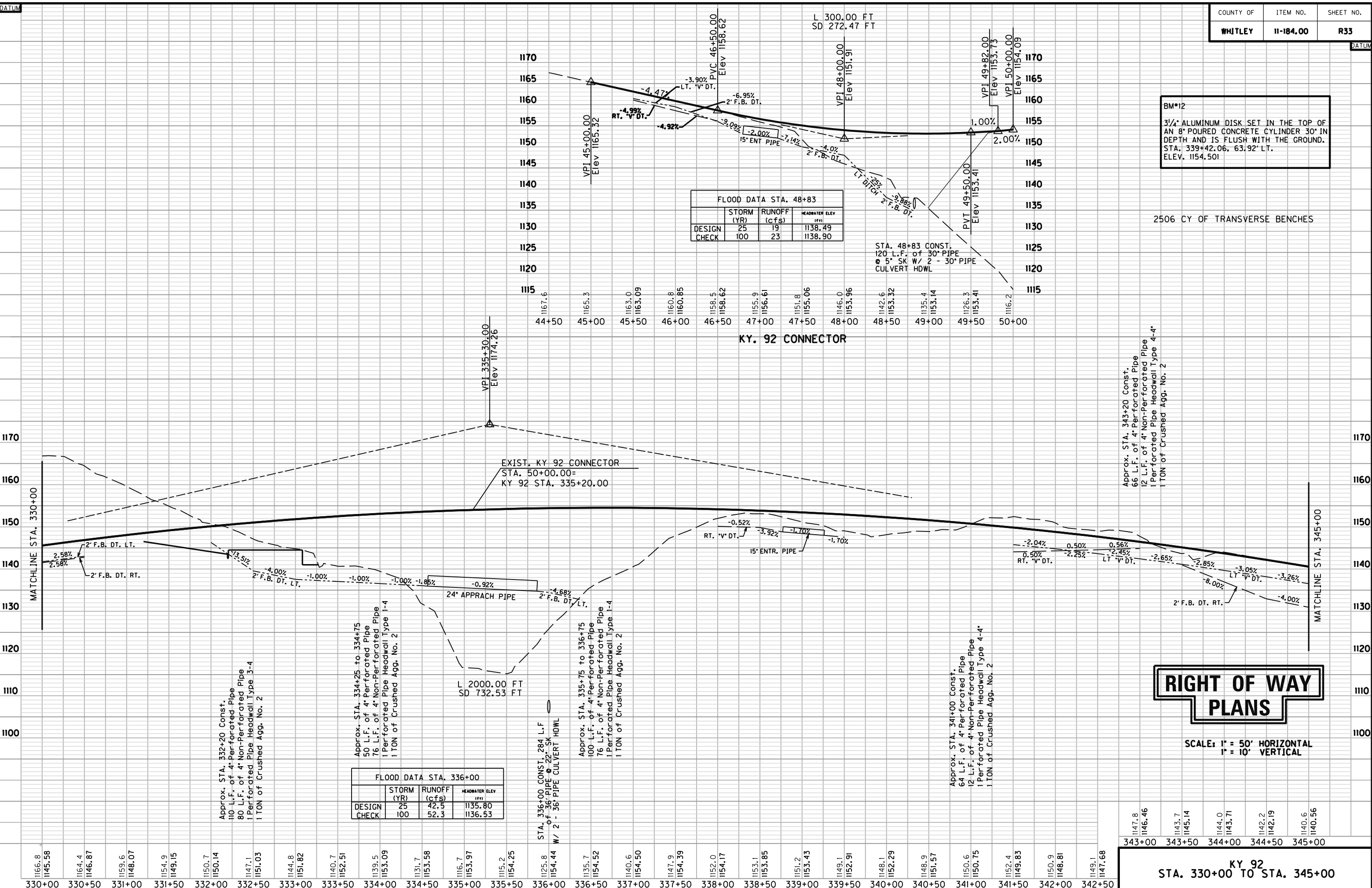

FLOOD DATA STA. 48+83

	STORM (YR)	RUNOFF (cfs)	HEADWATER ELEV (ft)
DESIGN	25	19	1138.49
CHECK	100	23	1138.90

FLOOD DATA STA. 336+00

	STORM (YR)	RUNOFF (cfs)	HEADWATER ELEV (ft)
DESIGN	25	42.5	1135.80
CHECK	100	52.3	1136.53

BM#12
 3/4" ALUMINUM DISK SET IN THE TOP OF AN 8" POURED CONCRETE CYLINDER 30" IN DEPTH AND IS FLUSH WITH THE GROUND. STA. 339+42.06, 63.92' LT. ELEV. 1154.501

2506 CY OF TRANSVERSE BENCHES

RIGHT OF WAY PLANS

SCALE: 1" = 50' HORIZONTAL
 1" = 10' VERTICAL

1147.8	1146.46	1143.7	1145.14	1144.0	1143.71	1142.2	1142.19	1140.6	1140.56
343+00	343+50	344+00	344+50	345+00					

STA. 330+00 TO STA. 345+00

COUNTY OF	ITEM NO.	SHEET NO.
WHITLEY	11-184.00	R34

KY 92
P.I. 343+25.05
 $\Delta = 11^{\circ}22'46"$ LT
T = 298.90'
L = 595.83'
R = 3000.00'
E = 14.85'
e = .043
Runoff = 165
Runout = 77
DESIGN SPEED 55 MPH

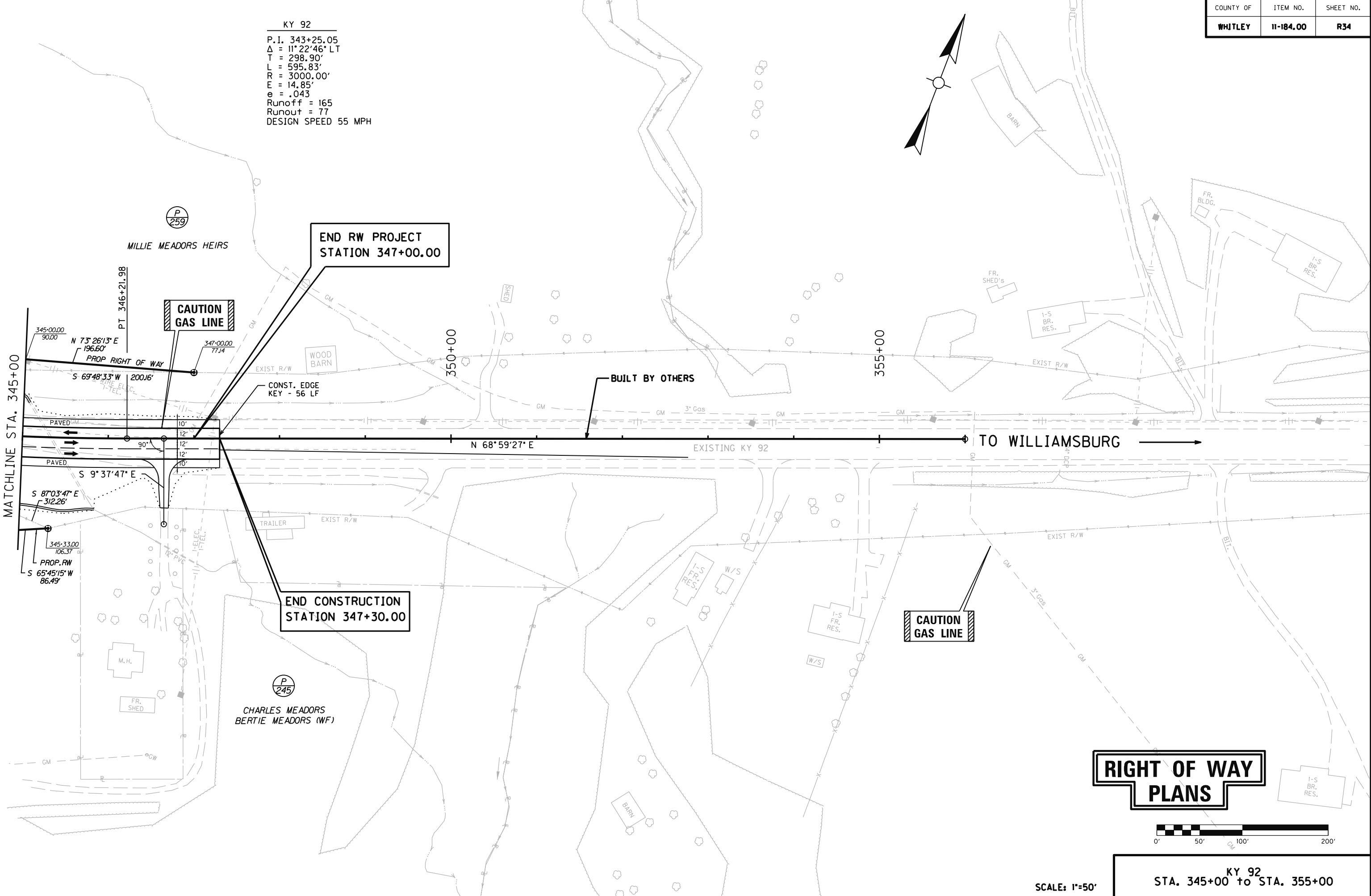
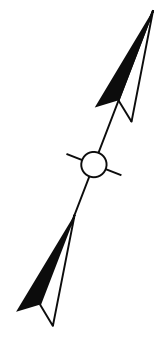

FILE NAME: G:\ENGR\HDIB5.0\PHASE II\CAD\PLANS\ROW\34500PL.DGN

USER: sdcvcty
DATE PLOTTED: June 20, 2013

E-SHEET NAME:

MicroStation v8.11.7.180

MILLIE MEADORS HEIRS

**END RW PROJECT
STATION 347+00.00**

**CAUTION
GAS LINE**

MATCHLINE STA. 345+00

**END CONSTRUCTION
STATION 347+30.00**

BUILT BY OTHERS

TO WILLIAMSBURG

**RIGHT OF WAY
PLANS**

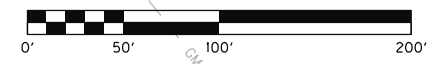

SCALE: 1"=50'

KY 92
STA. 345+00 to STA. 355+00

MicroStation v8.11.7.180 E-SHEET NAME: USER: sdcgcty DATE PLOTTED: June 20, 2013 FILE NAME: G:\ENGR\H085.01\PHASE 11\CAD\PLANS\ROW\34500PR.DGN

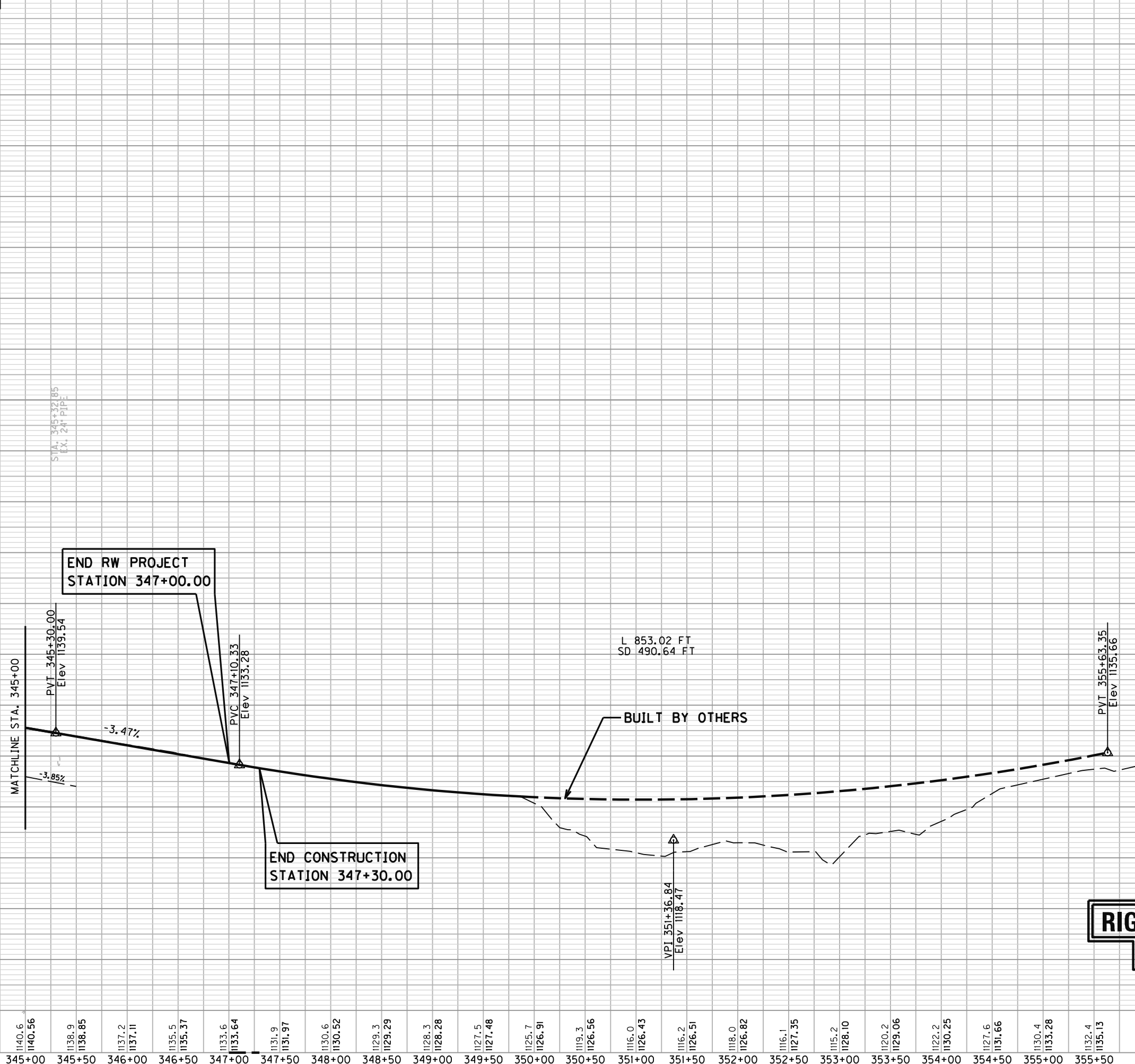

SCALE: 1" = 50' HORIZONTAL
1" = 10' VERTICAL

STA. 345+00 TO STA. 356+00
KY 92

MicroStation v8.11.7.180
 E-SHEET NAME:
 USER: HAYSON
 DATE PLOTTED: June 20, 2013
 FILE NAME: G:\ENGR\H0185.0\PHASE 1\ACAD\PLANS\ROW\ENTPROFILES.DGN

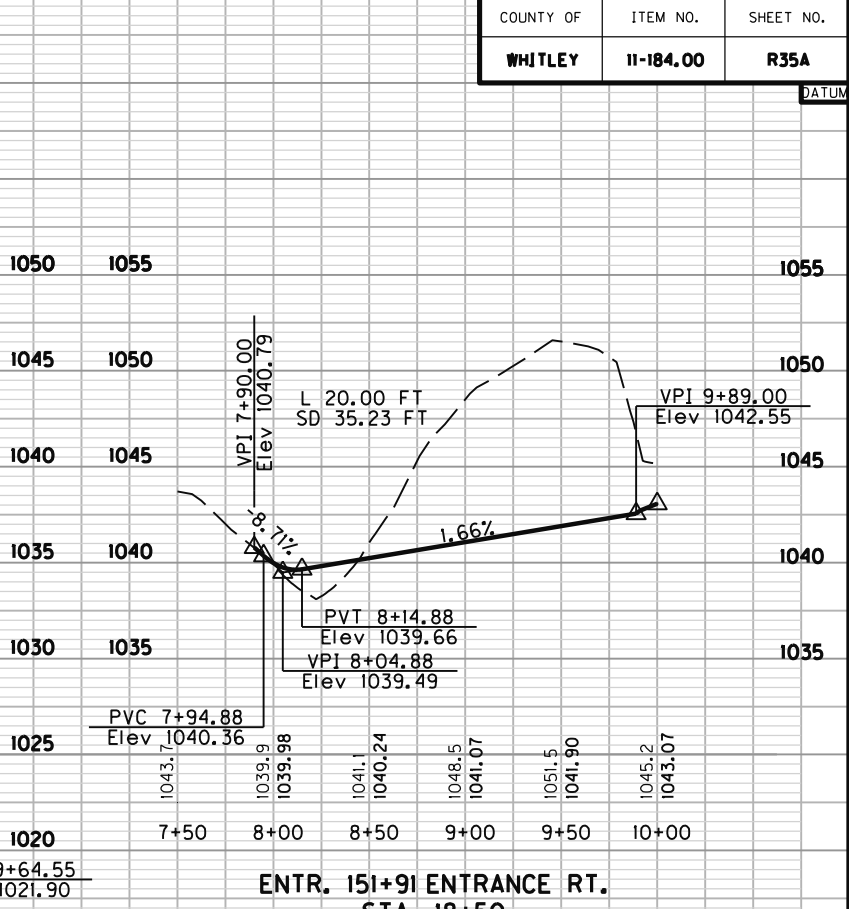
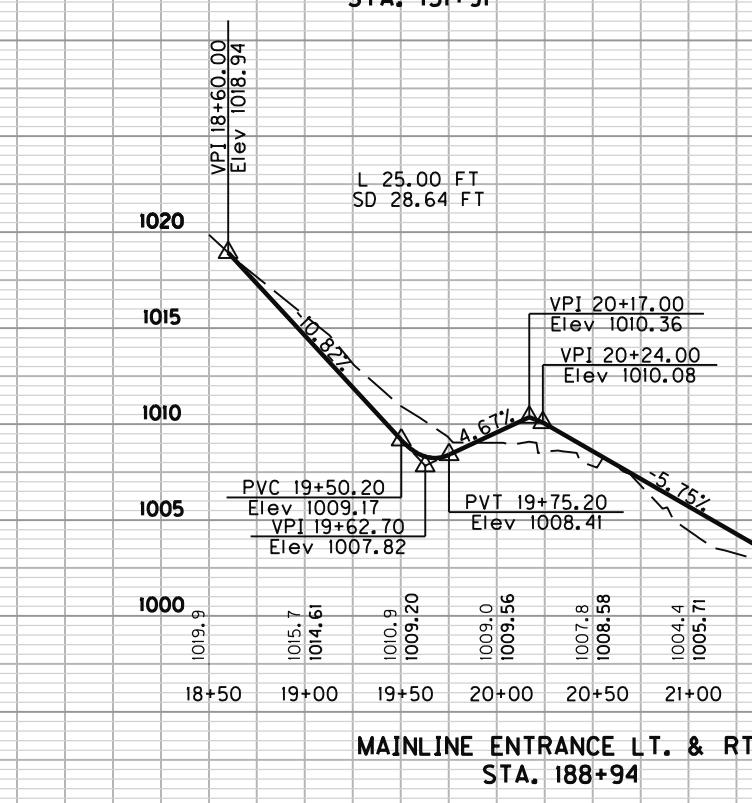
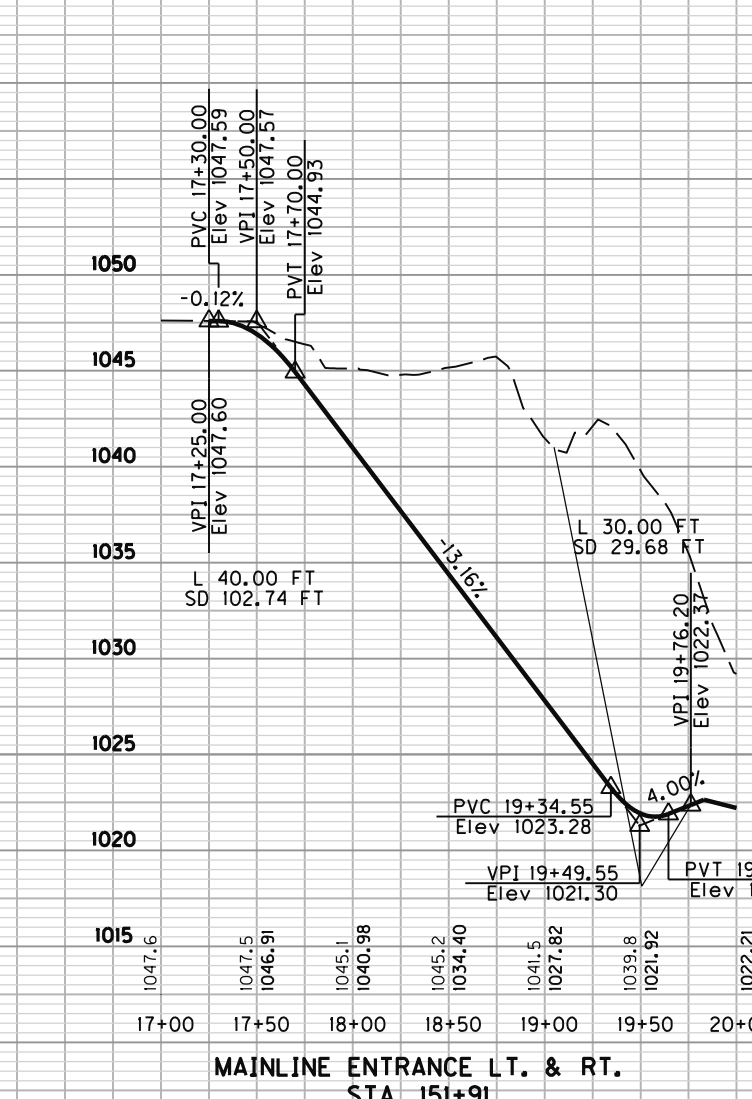
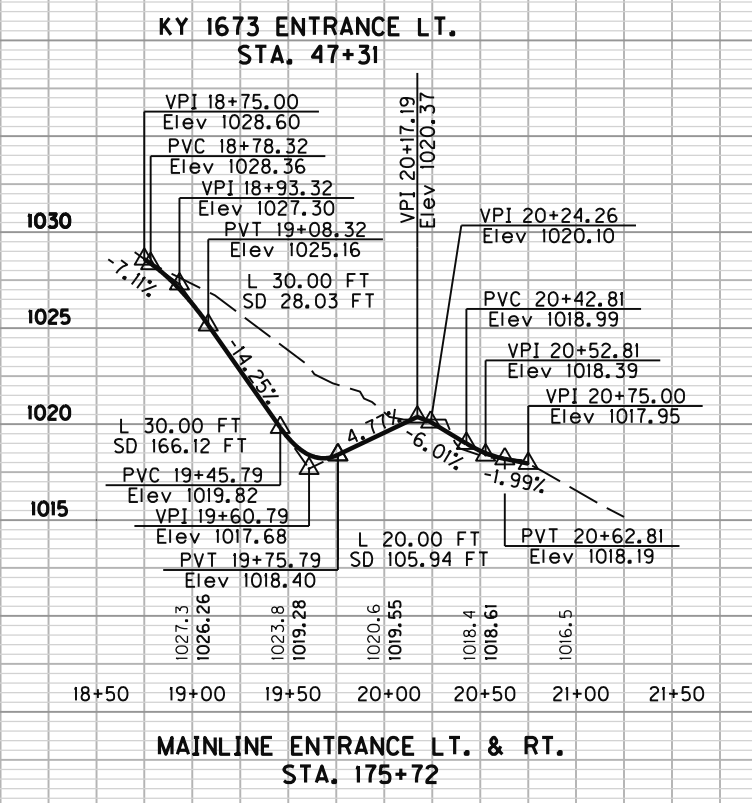
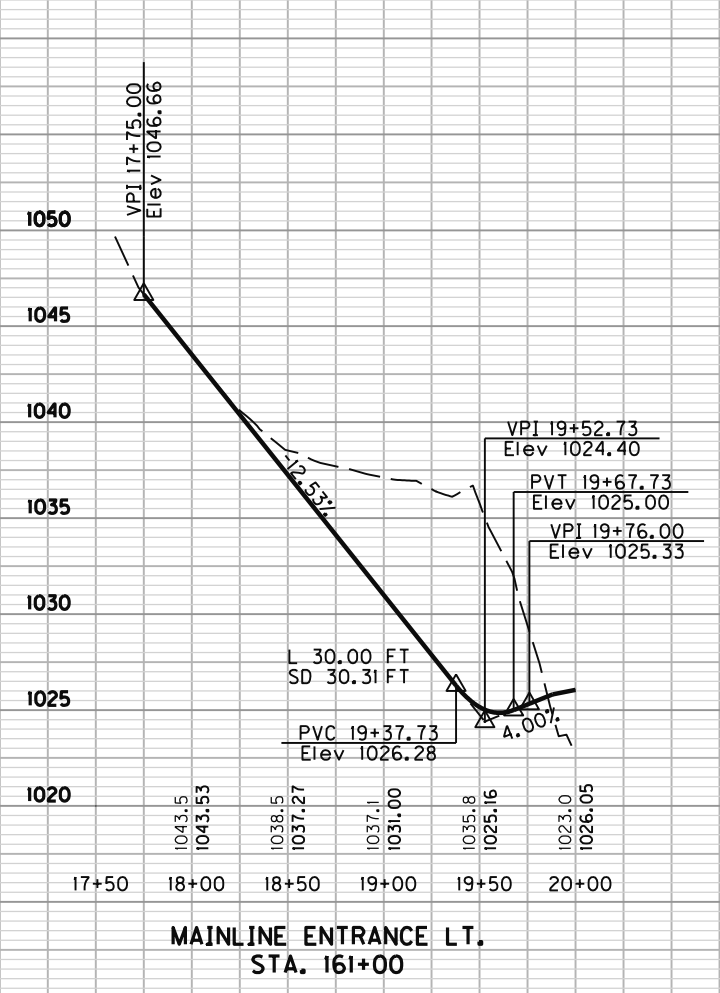
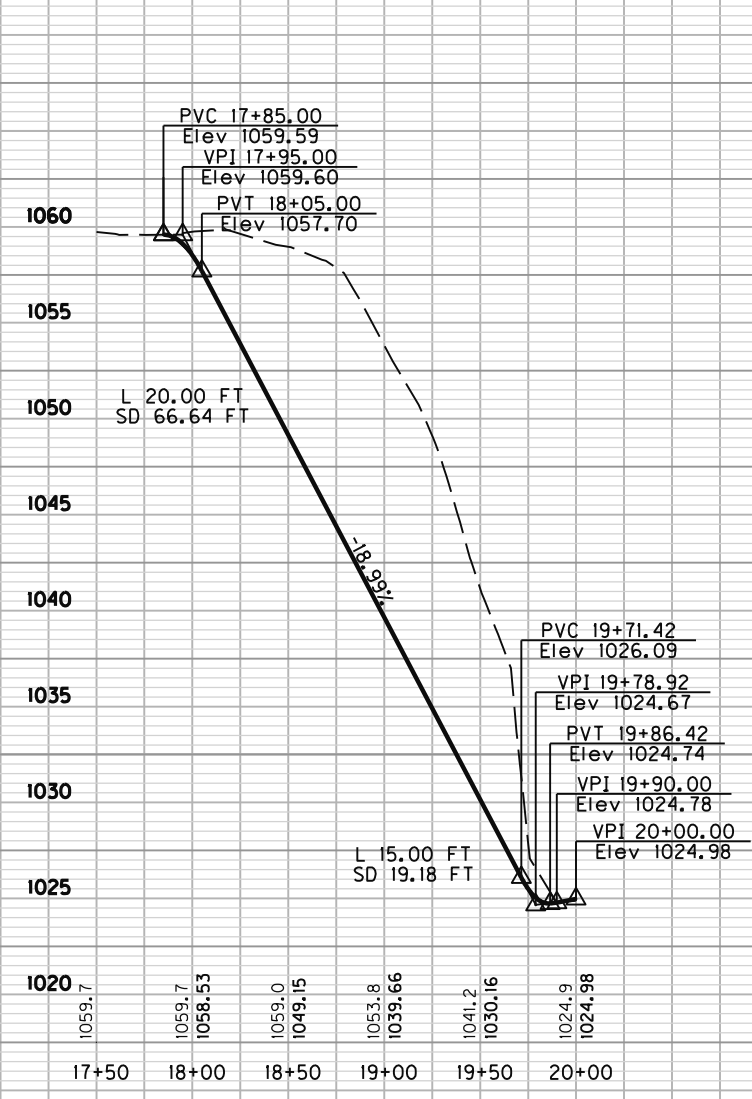
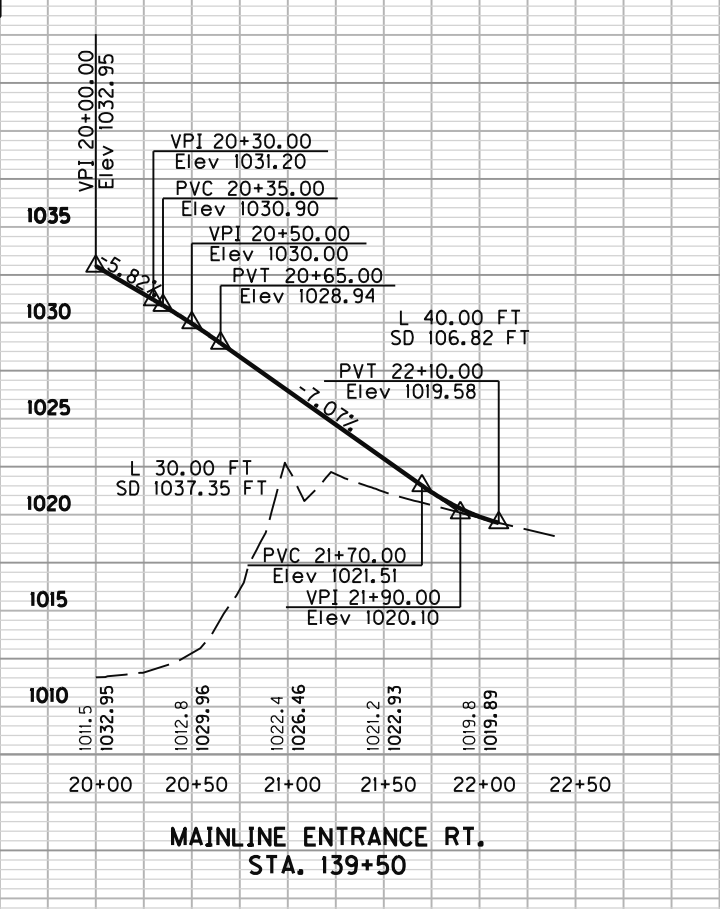

RIGHT OF WAY PLANS

SCALE: 1" = 50' HORIZONTAL
1" = 10' VERTICAL

ENTRANCE PROFILES

DATUM
 FILE NAME: G:\ENGR\H0185.01\PHASE II\CAD\PLANS\ROW\ENTPROFILES.DGN
 USER: HAYSON
 DATE PLOTTED: June 20, 2013
 E-SHEET NAME:
 MicroStation v8.11.7.180

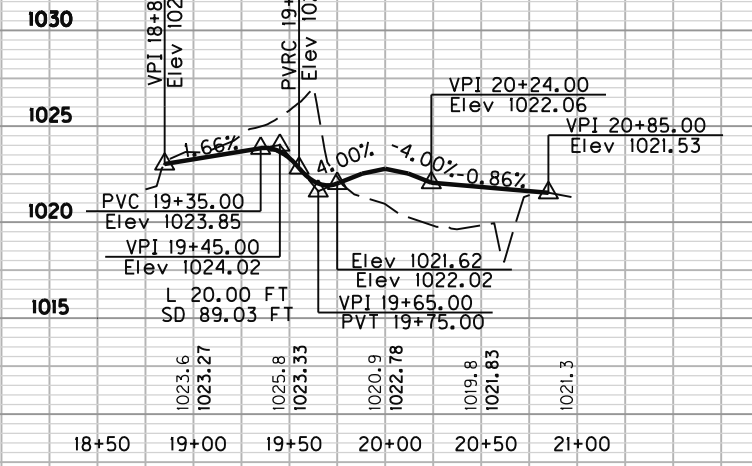
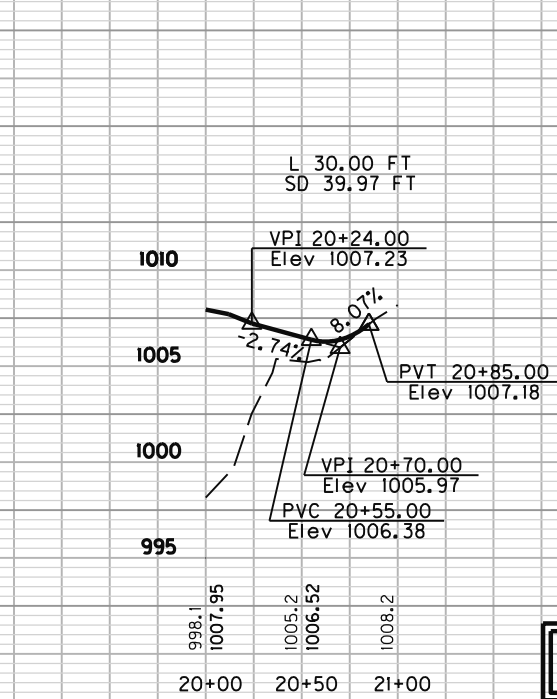
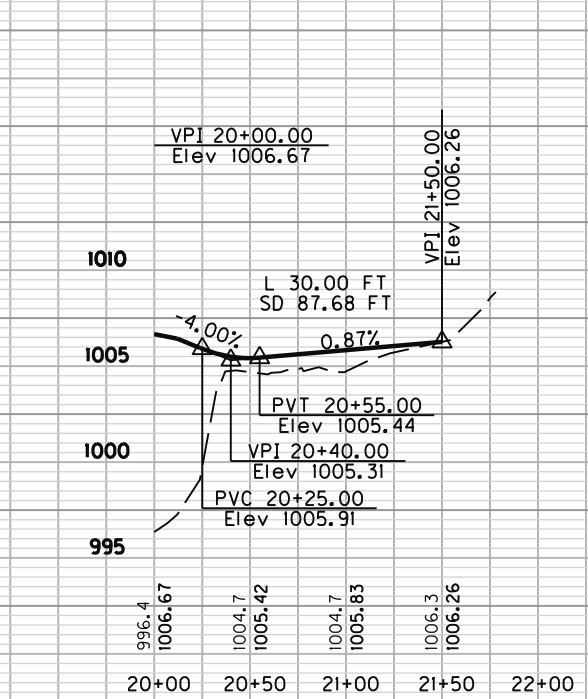
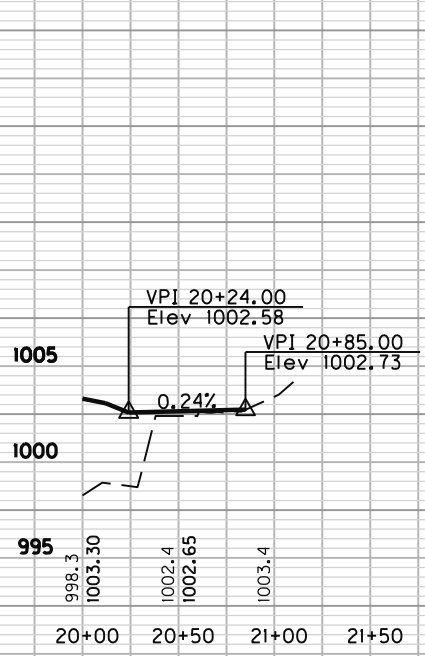
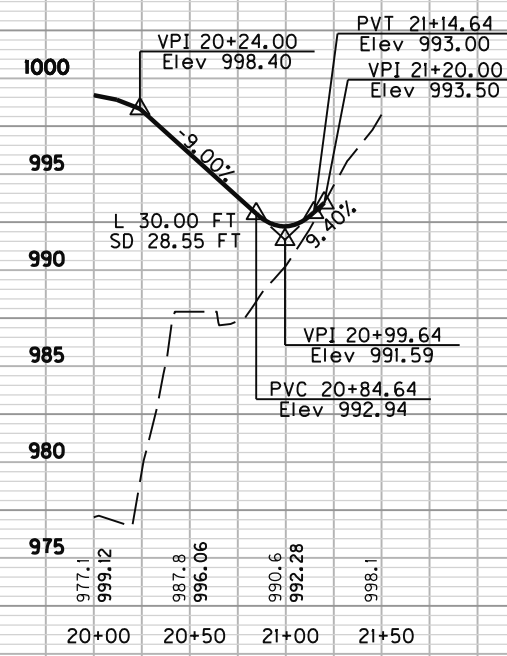
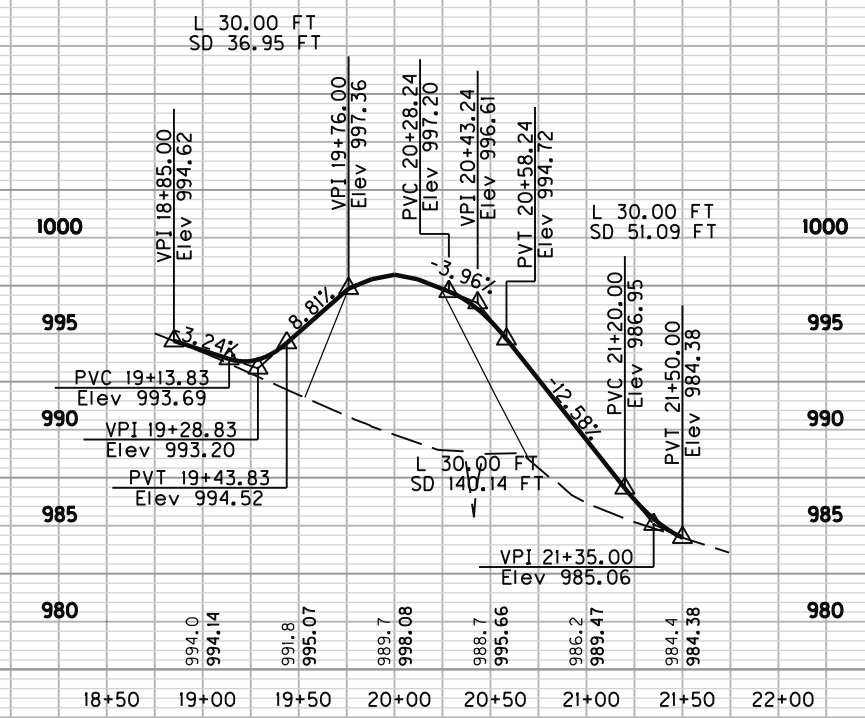
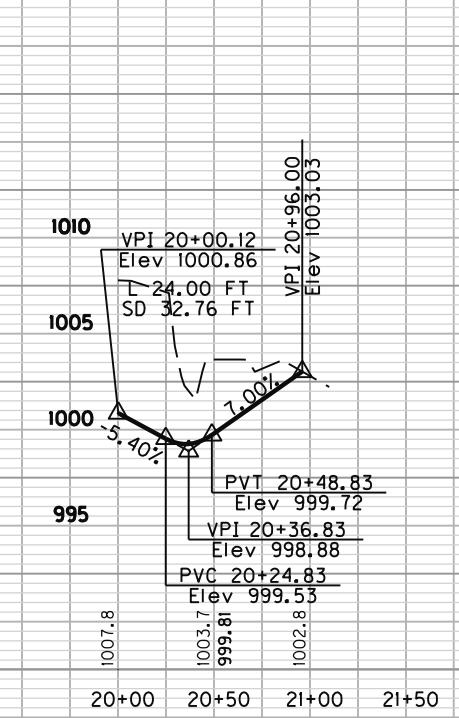
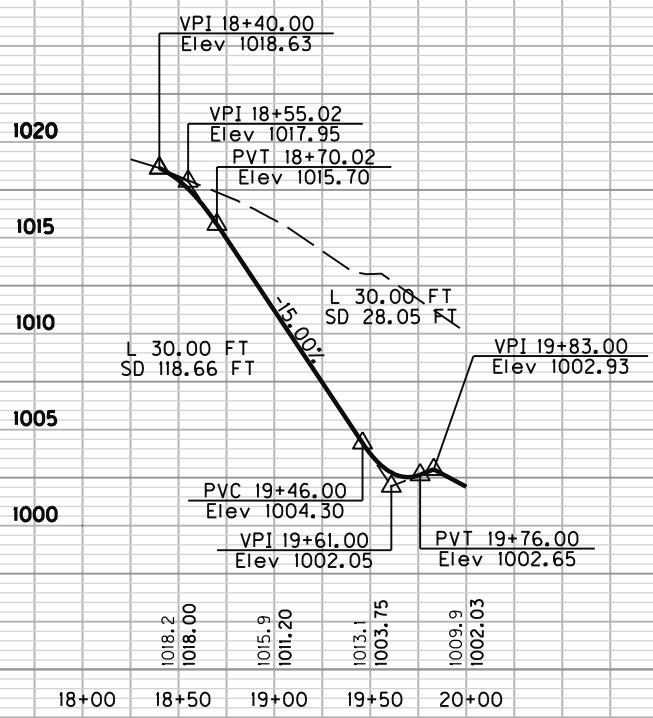
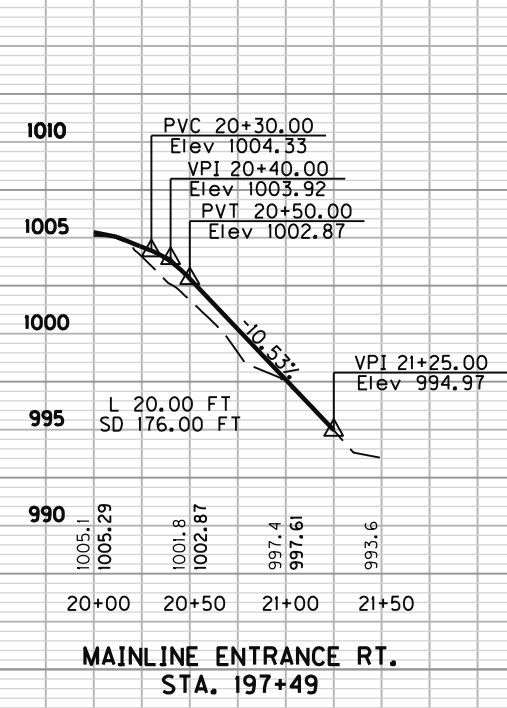

RIGHT OF WAY
 PLANS

SCALE: 1" = 50' HORIZONTAL
 1" = 10' VERTICAL

ENTRANCE PROFILES

MicroStation v8.11.7.180
 E-SHEET NAME:
 USER: tloyson
 DATE PLOTTED: June 20, 2013
 FILE NAME: G:\ENGR\H0185.01\PHASE 11\CAD\PLANS\ROW\ENTPROFILES.DGN

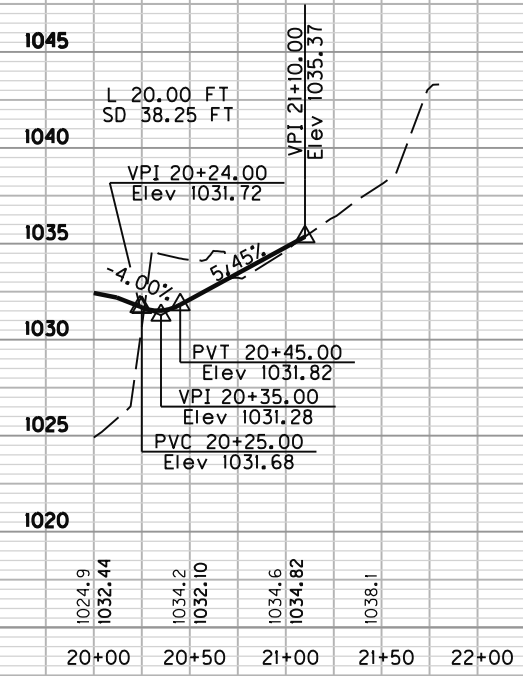

**MAINLINE ENTRANCE RT.
STA. 235+47.50**

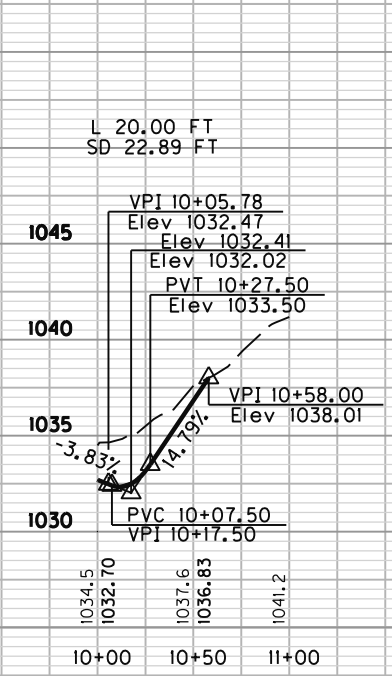

**ENTR. 235+47.50 ENTRANCE RT.
STA. 20+61.25**

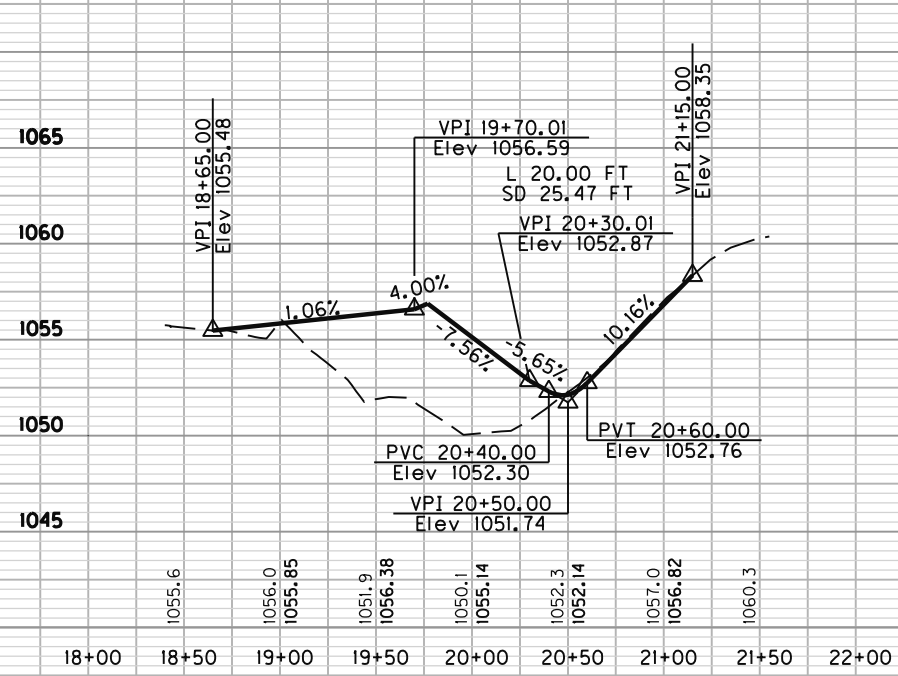

**MAINLINE ENTRANCE LT. & RT.
STA. 248+25**

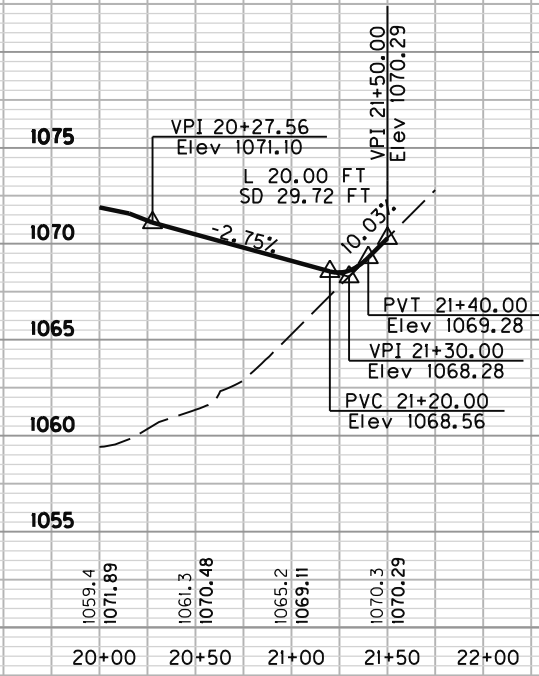

**MAINLINE ENTRANCE RT.
STA. 260+00**

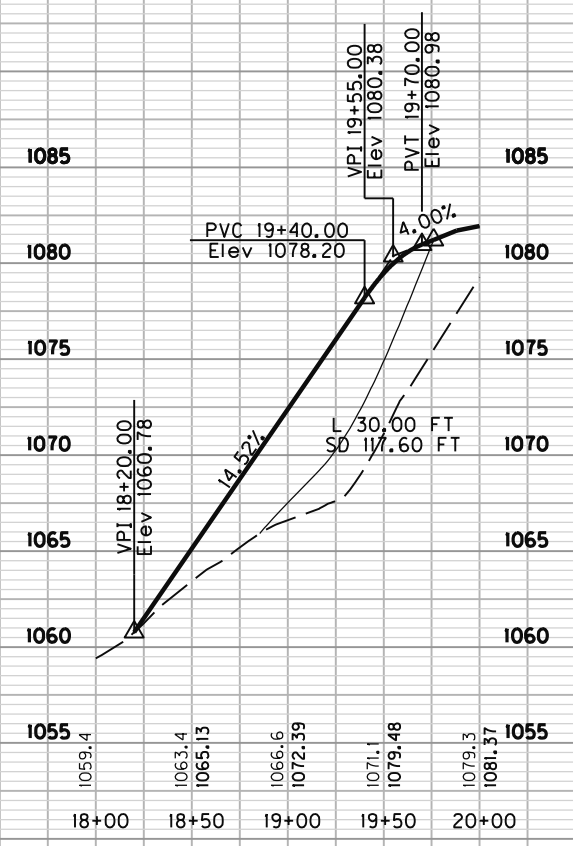

**MAINLINE ENTRANCE LT.
STA. 262+75**

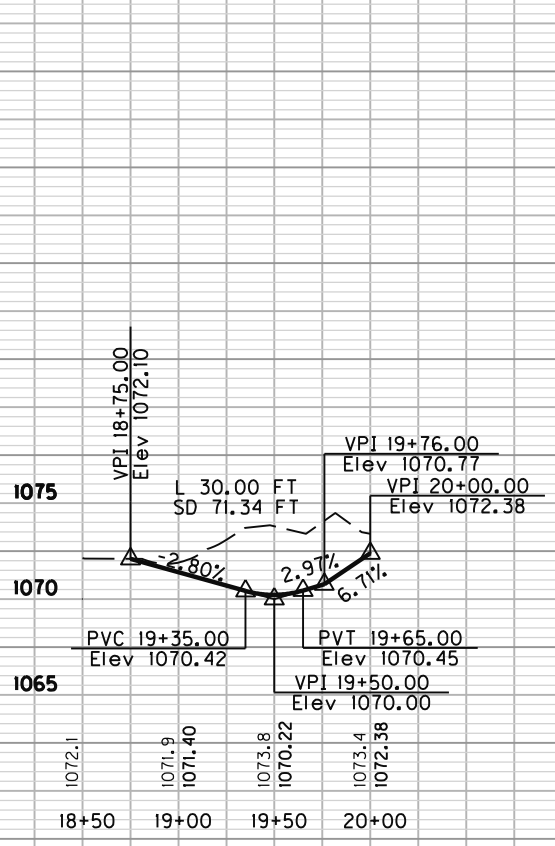

**MAINLINE ENTRANCE LT.
STA. 283+00**

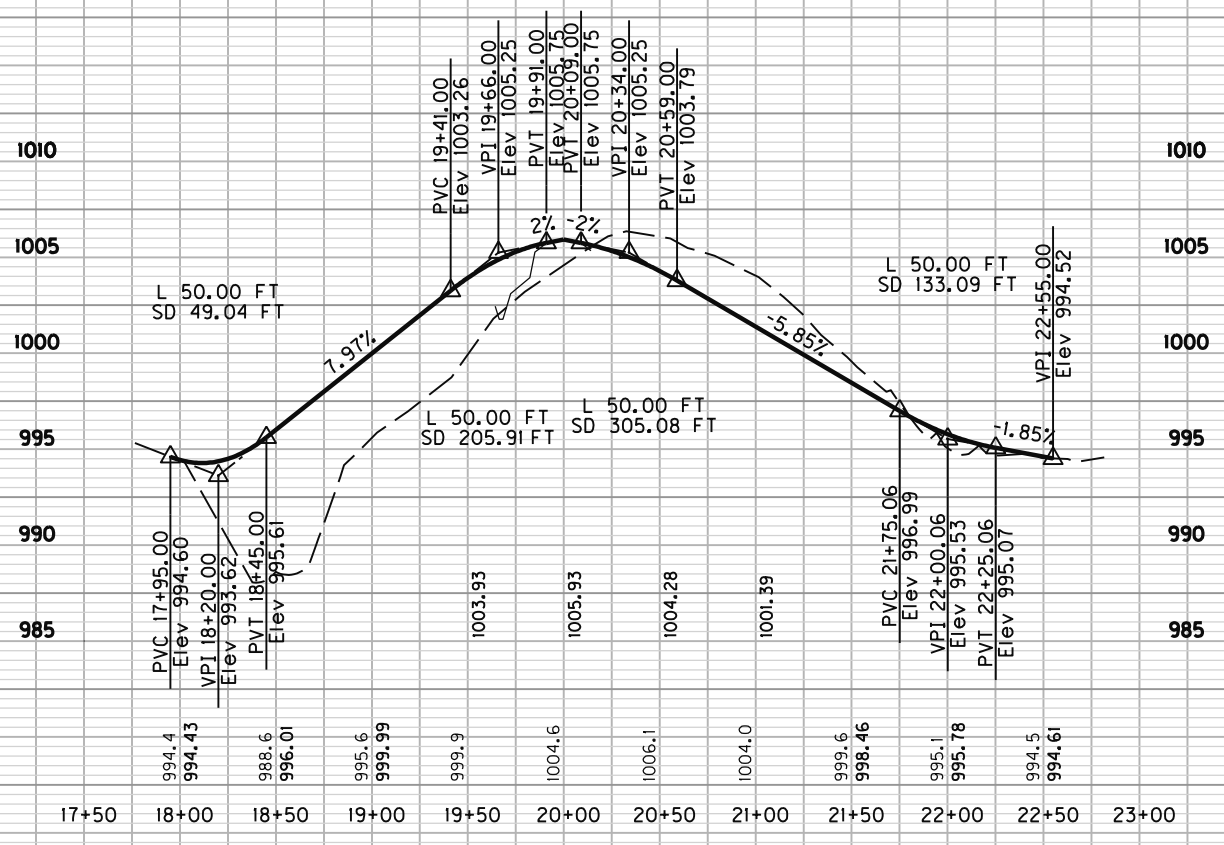

**MAINLINE ENTRANCE
STA. 46+30
(OFF FRONTAGE RD CONNECTOR)**

**RIGHT OF WAY
PLANS**

SCALE: 1" = 50' HORIZONTAL
1" = 10' VERTICAL

ENTRANCE PROFILES

MicroStation v8.11.7.180
 E-SHEET NAME:
 USER: HAYSON
 DATE PLOTTED: June 20, 2013
 FILE NAME: G:\ENGR\H085.0\PHASE 11\CAD\PLANS\ROW\ENTPROFILES.DGN

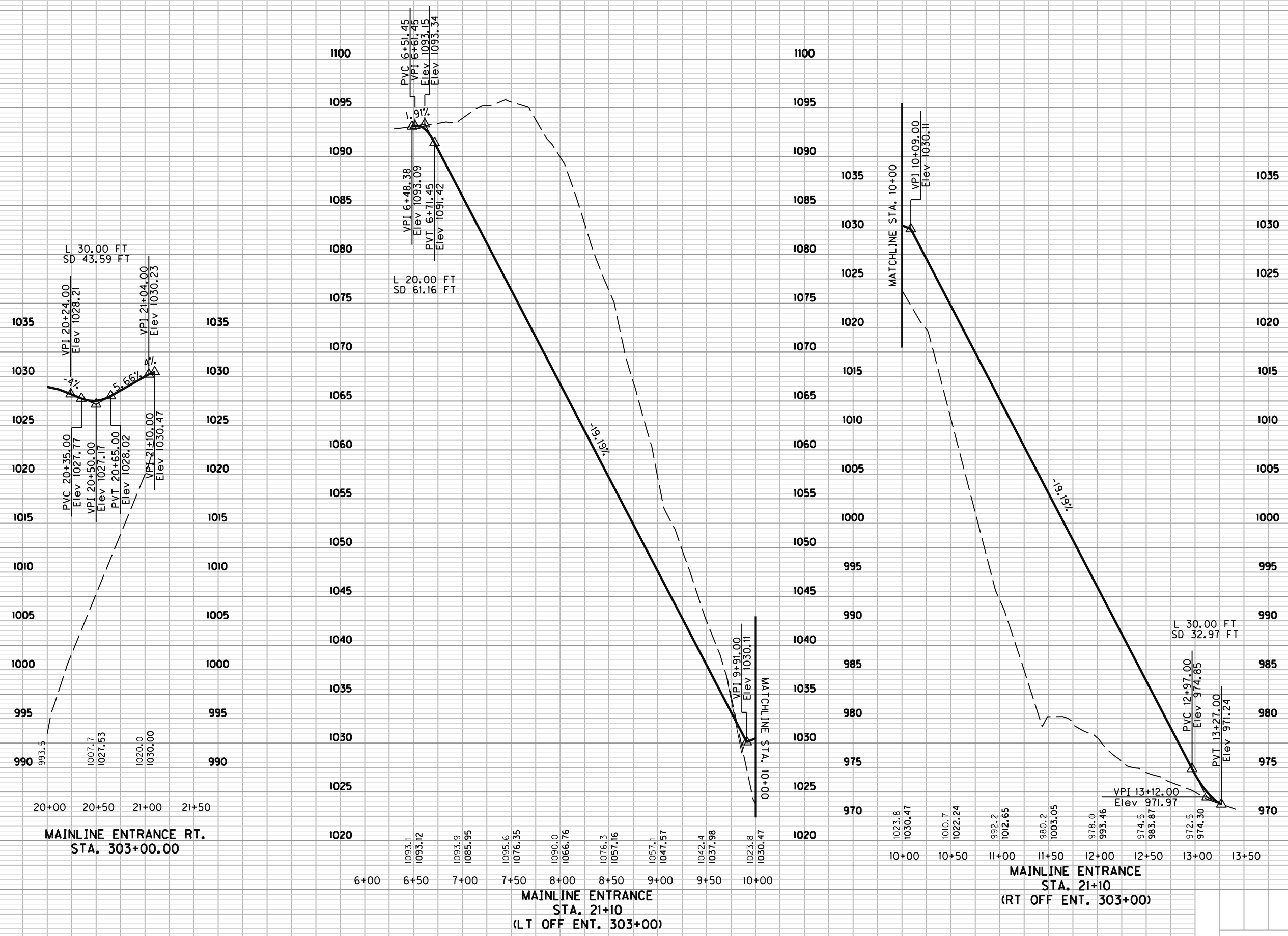

RIGHT OF WAY PLANS

SCALE: 1" = 50' HORIZONTAL
1" = 10' VERTICAL

ENTRANCE PROFILES

MicroStation v8.11.7.180 E-SHEET NAME: DATE PLOTTED: June 20, 2013 USER: HAYSON FILE NAME: G:\ENGR\H0185_01\PHASE 1\ACAD\PLANS\ROW\ENTPROFILES.DGN

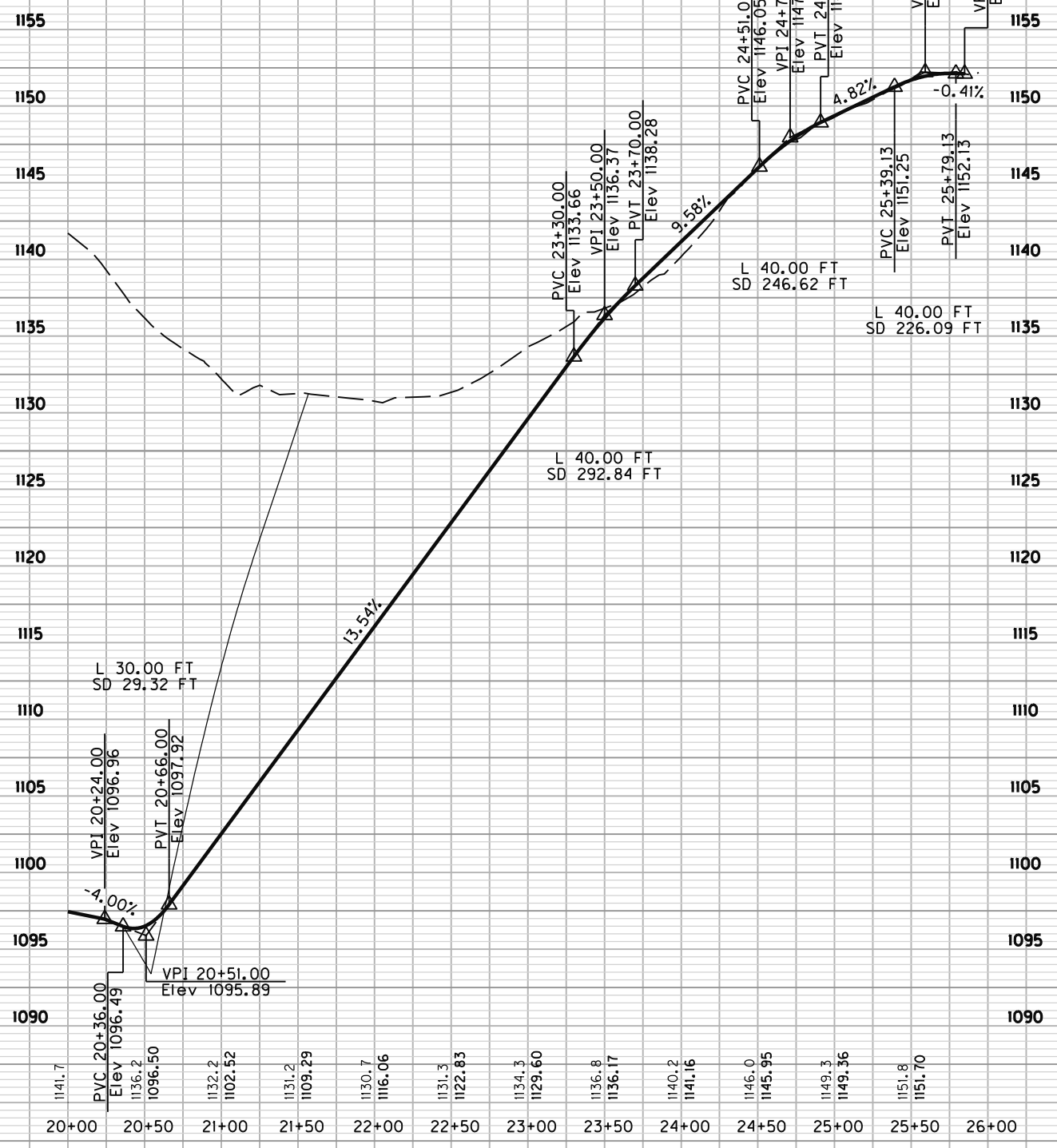
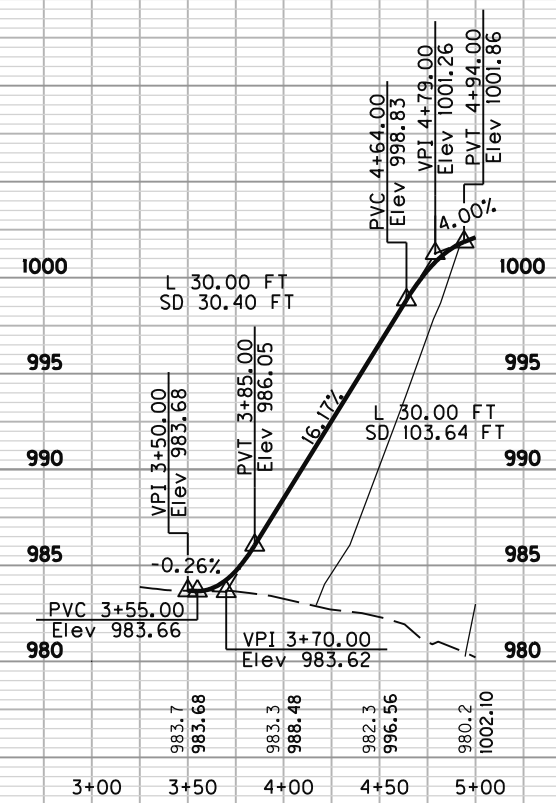

**RIGHT OF WAY
PLANS**

SCALE: 1" = 50' HORIZONTAL
1" = 10' VERTICAL

ENTRANCE PROFILES

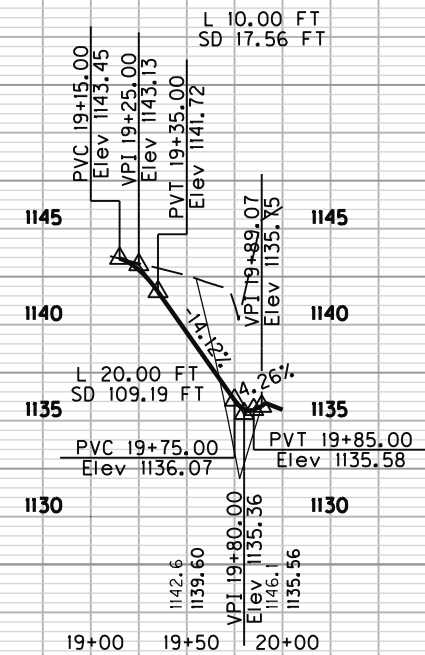

OLD JELICO CREEK RD. ENTRANCE LT.
STA. 51+36

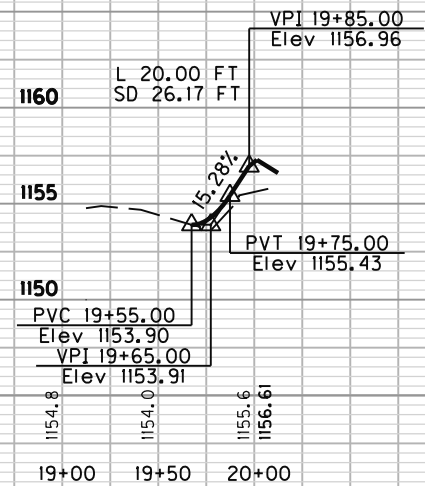

KY 92 CONN. #2 ENTRANCE LT.
STA. 47+00

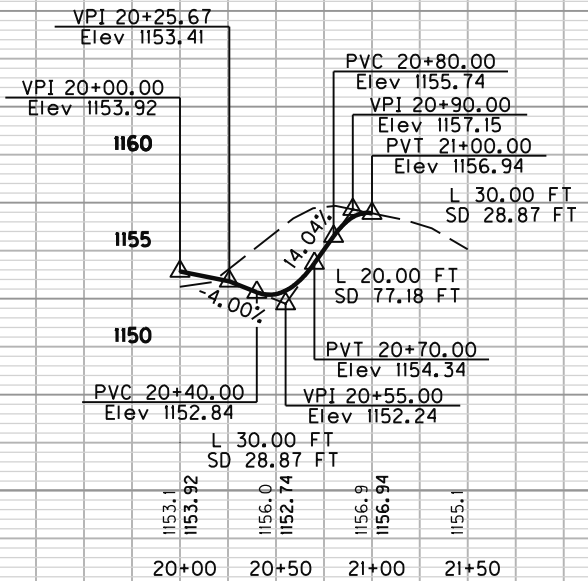

MAINLINE ENTRANCE RT.
STA. 338+40

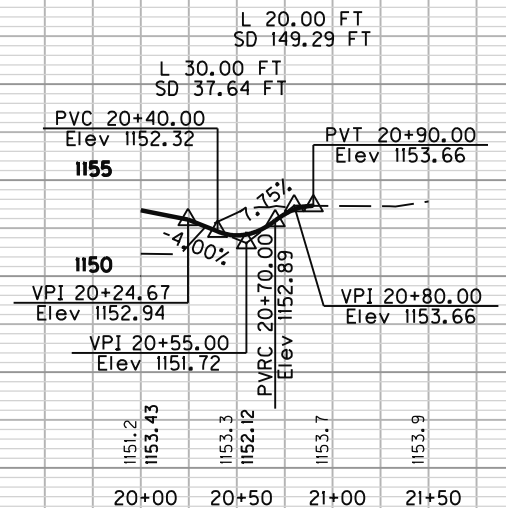

MAINLINE ENTRANCE RT.
STA. 339+00

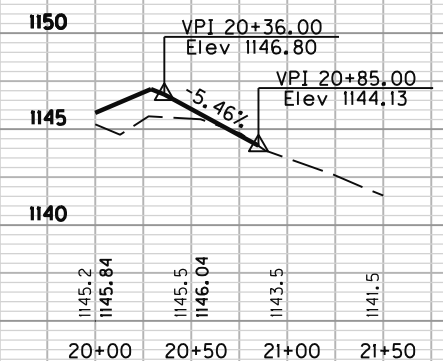

MAINLINE ENTRANCE RT.
STA. 343+24

**RIGHT OF WAY
PLANS**

SCALE: 1" = 50' HORIZONTAL
1" = 10' VERTICAL

ENTRANCE PROFILES

DATUM
 FILE NAME: G:\ENGR\H0185.01\PHASE 1\CAD\PLANS\ROW\ENTPROFILES.DGN
 USER: HAYSON
 DATE PLOTTED: June 20, 2013
 E-SHEET NAME:
 MicroStation v8.11.7.180

RIGHT OF WAY SUMMARY

PARCEL NO.	OWNER(S)	TOTAL AREA OF TRACT		PERMANENT R/W ACQUIRED		EASEMENTS		AREA SEVERED				EXCESS PURCHASED		PORTION REMAINING		SEWER SYSTEM TYPE	SEWER SYSTEM AFFECTED BY PROJECT		BUILDINGS ACQUIRED NUMBER					SOURCE OF TITLE	REMARKS*
		ACRES	SQ. FT.	ACRES	SQ. FT.	PERMANENT SQ. FT.	TEMPORARY SQ. FT.	LEFT		RIGHT		ACRES	SQ. FT.	ACRES	SQ. FT.		YES	NO	C	R	F	S			
								ACRES	SQ. FT.	ACRES	SQ. FT.														
195	ELISHA D. MAXWELL & ASHLEY L. JONES																						SEE McCREARY COUNTY SECTION PARCEL 129		
196-199	NOT USED	NOT	USED	NOT	USED					NOT	USED												NOT USED		
200	RONNIE PATRICK (1/2 INTEREST), DONNIE PATRICK (1/4 INTEREST), DONNIE BRUCE PATRICK (1/4 INTEREST)																						SEE McCREARY COUNTY SECTION PARCEL 116		
201	BOBBY K. MAYS FREDA MAYS (WF)	103.610	C	2.132		17666		53.689		47.789					5								DB 360 PG 267 DB 126 PG 51 DB 137 PG 606 SEE McCREARY CO. SECTION PARCEL 122		
202	HAMP CRIT HIGGINBOTHAM PATRICIA L. HIGGINBOTHAM (WF)	3.349	C	3.349											1	X							DB 271 PG 521 TOTAL TAKE		
203	HAMP CRIT HIGGINBOTHAM BETTIE RUTH JONES	100	O	6.796			51670	90.987		2.217					1	X							DB 321 PG 115		
204	GEORGE HARLAN CADDELL	363.159	C	16.748		7866	23674	101.664		244.747					5								DB 478 PG 139 WB 23 PG 549 DB 405 PG 23 DB 174 PG 174 DB 172 PG 179 DB 446 PG 201		
205	NOT USED	NOT	USED																				NOT USED		
206	PAUL ROWE DELORES ROWE (WF)	512.106	C	11.191		7087	25161	392.387		108.528					5								DB 442 PG 690 DB 417 PG 227 DB 407 PG 218 DB 361 PG 277 MB 94 PG 662		
207-208	NOT USED	NOT	USED	NOT	USED					NOT	USED												NOT USED		
209	PAUL ROWE DELORES ROWE (WF)	1.405	C				4534			1.405					1	X							DB 468 PG 638 ABANDONED 1 STY FRAME		
210	CONNIE LYNN HATLAND	16.181	C	4.406			1765	11.775							1		X						DB 506 PG 743 DB356 PG70 DB346 PG134 DB344 PG439		
211	MARK LAWSON	7.521	C				2139			7.521					5								DB 330 PG 442		
212	KENNETH LAWSON BLANCHE LAWSON (WF)	1.984	C				6028			1.984					1	X							DB 307 PG 603 SEPTIC LINES PARTIALLY ON EXIST RW & ADJOINING PROPERTY		
213	CLIFFORD J. PARTIN	75.000	O	7.380			5439	62.534		5.086					5								DB 410 PG 596		
214-215	NOT USED	NOT	USED	NOT	USED					NOT	USED												NOT USED		
216	GARY BAJRD ANNA BAJRD (WF)	4.869	C	0.247	10760		2635			4.622					1		X						DB 453 PG 359 DB 451 PG 590 DB 386 PG 576		
217	THEODORE MOSES EDNA MOSES	150.730	C	25.577		9251	11597	107.798		17.355					1	X					2	5	DB 309 PG 360 DB 288 PG 135 SEPTIC LINE UNDER ROADWAY FILL		
218-222	NOT USED	NOT	USED	NOT	USED					NOT	USED												NOT USED		
223	LEE WARREN MARIA WARREN (WF)	5.748	C	1.490						4.463					5								DB 427 PG 31		
224-230	NOT USED	NOT	USED	NOT	USED					NOT	USED												NOT USED		
231	CECIL WAYNE MEADORS	3.943	C	1.907						2.036					1	X							3 DB 381 PG 68 CAP WELL (1)		
232	NOT USED	NOT	USED	NOT	USED					NOT	USED												NOT USED		
233	DUELL LESTER	41.349	C	7.397			7512	33.952		0					1	X							1 1 2 DB 238 PG 409		
234	DELMER LESTER WILMA LESTER (WF)	2.436	C	2.436				0		0					1	X							1 1 DB 221 PG 545 TOTAL TAKE		
235	PAUL CAMPBELL ALICE CAMPBELL (WF)	1.231	C	0.984	42864				0.247 LL	10763 LL					1	X							1 DB 321 PG 454		
236	DANIEL WAYNE CAMPBELL CATHERINE CAMPBELL (WF)	10.779	C	4.459			18730			6.320					4								DB 504 PG 187		
237	JOYCE STEPHENS	22.669	C	7.072			3714	11.915		3.682					5								DB 213 PG 39 WB 24 PG 402 DB 168 PG 18		
238	VERNON STEPHENS JEWELL D. STEPHENS (WF)	18.785	C	10.370			1596			8.415					5								DB 204 PG 441		
239	CHRISTAL & JAMES LEWIS	0.479	20850 C	0.351	15278					0.128 LL	5572 LL				1	X							1 2 DB 501 PG 226 CAP WELL (1)		

FILE NAME: G:\ENGR\HDIB5.0\PHASE 1\ACAD\PLANS\ROW\ROWSUM.DGN
 USER: HOYSON
 DATE PLOTTED: June 20, 2013
 E-SHEET NAME:
 MicroStation v8.11.7.180

NOTE: PERMANENT R/W ACQUIRED + AREA SEVERED = TOTAL AREA OF TRACT.



- ① BASIS FOR DETERMINATION OF AREA:
- a. DEED
 - b. P.V.A.
 - c. CALCULATED
 - d. OTHER

- TYPE SEWER SYSTEM
- 1. PRIVATE - INDIVIDUAL
 - 2. PRIVATE - MULTI PARTY
 - 3. PUBLIC
 - 4. NONE
 - 5. NOT APPLICABLE

- BUILDINGS ACQUIRED CODE
- C - COMMERCIAL
 - R - RESIDENTIAL
 - F - FARM
 - S - STORAGE

*INCLUDES HAZARDOUS WASTE (JUST - UNDERGROUND STORAGE TANKS)

RIGHT OF WAY SUMMARY

PARCEL NO.	OWNER(S)	TOTAL AREA OF TRACT		PERMANENT R/W ACQUIRED		EASEMENTS		AREA SEVERED				EXCESS PURCHASED		PORTION REMAINING		SEWER SYSTEM TYPE	SEWER SYSTEM AFFECTED BY PROJECT		BUILDINGS ACQUIRED NUMBER					SOURCE OF TITLE	REMARKS*
		ACRES	SQ. FT.	ACRES	SQ. FT.	PERMANENT SQ. FT.	TEMPORARY SQ. FT.	LEFT		RIGHT		ACRES	SQ. FT.	ACRES	SQ. FT.		YES	NO	C	R	F	S			
								ACRES	SQ. FT.	ACRES	SQ. FT.														
240	NOT USED	NOT	USED	NOT	USED					NOT	USED			NOT	USED									NOT USED	
241	MELVINA M. HOLT	22.5	0				3280	22.5						22.5		1	X							DB 466 PG 88	
242	MORRIS SHELLEY WADIE MAE SHELLEY (WF)	27.614	C	8.706			13336	8.774		10.134				19.908		1	X			1	1			DB 329 PG 222	
243	NOT USED	NOT	USED	NOT	USED					NOT	USED			NOT	USED									NOT USED	
244	VERNON STEPHENS JEWELL D. STEPHENS (WF)	2.536	C	0.951	41425		3459			1.585				1.585		1	X			2	5			DB 359 PG 201 CAP WELL (1)	
245	CHARLES MEADORS BERTIE MEADORS (WF)	12.068	C	0.661	28797		847			11.407				11.407		1	X			1	1			DB 234 PG 494	
246	NOT USED	NOT	USED	NOT	USED					NOT	USED			NOT	USED									NOT USED	
247	STEVEN J. CAMPBELL TAMMY SUE CAMPBELL (WF)	55.449	C	3.483			2900	51.970						51.970		1	X							DB 388 PG 64 DB 276 PG 296	
248	DEANNA MYERS MARTIN MYERS (HUSB)	5	0	0.631	27490		5200			4.369				4.369		1	X							DB 433 PG 324	
249	NOT USED	NOT	USED	NOT	USED					NOT	USED			NOT	USED									NOT USED	
258	THOMAS E. CAMPBELL TERESA CAMPBELL (WF)	6.472	C	0.125	5449		4849			6.347				6.347		1	X							DB 471 PG 90	
259	MILLIE MEADORS HEIRS	79.287	C	0.258	11236					79.029				79.029		5								WB 19 PG 290 DB 183 PG 430	
260	MATTHEW RATLIFF ASHLEY ALDER RATLIFF (WF)	39.155	0			1649	7035							39.155										DB 470 PG 658	
261	RICHARD WAYNE BAIRD	0.813	C	35415			2132			0.813	35415			0.813	35415	1	X							DB 472 PG 619	
262	DALE SNYDER	0.177	C	7699	0.177	7699			0	0				0		1	X				1			DB 443 PG 413 TOTAL TAKE	

FILE NAME: G:\ENGR\HDIB5.0\PHASE 1\ACAD\PLANS\ROW\ROWSUM.DGN

USER: HAYSON
DATE PLOTTED: June 20, 2013

E-SHEET NAME:

MicroStation v8.11.7.180

NOTE: PERMANENT R/W ACQUIRED + AREA SEVERED = TOTAL AREA OF TRACT.

RIGHT OF WAY PLANS

TYPE SEWER SYSTEM
 1. PRIVATE - INDIVIDUAL
 2. PRIVATE - MULTI PARTY
 3. PUBLIC
 4. NONE
 5. NOT APPLICABLE

BUILDINGS ACQUIRED CODE
 C - COMMERCIAL
 R - RESIDENTIAL
 F - FARM
 S - STORAGE

*INCLUDES HAZARDOUS WASTE
(UST - UNDERGROUND STORAGE TANKS)

COUNTY OF	ITEM NO.	SHEET NO.
WHITLEY	11-184.00	R38

RIGHT OF WAY STRIP MAP

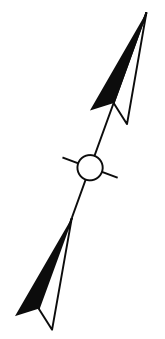

FILE NAME: G:\ENGR\HDIB5.0\PHASE 1\ACAD\PLANS\ROW\RWSTRIP1.DGN
 USER: sdcgcty
 DATE PLOTTED: June 20, 2013
 E-SHEET NAME:
 MicroStation v8.11.7.180

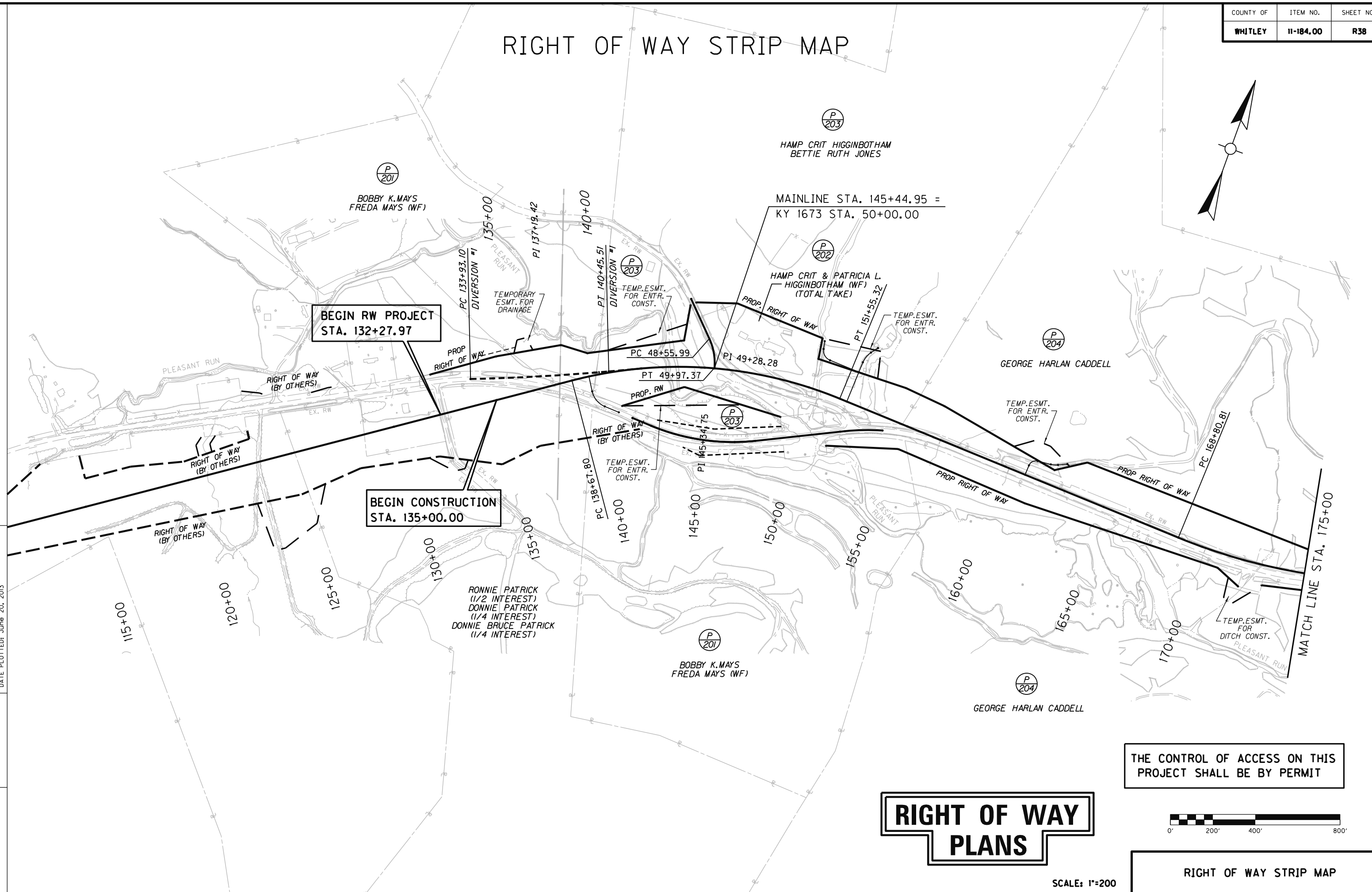

THE CONTROL OF ACCESS ON THIS PROJECT SHALL BE BY PERMIT

RIGHT OF WAY PLANS



RIGHT OF WAY STRIP MAP

SCALE: 1"=200'

COUNTY OF	ITEM NO.	SHEET NO.
WHITLEY	11-184.00	R39

RIGHT OF WAY STRIP MAP

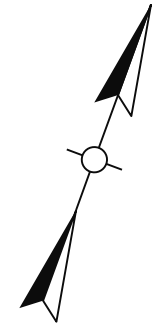

FILE NAME: G:\ENGR\HD185.0\PHASE 1\ACAD\PLANS\ROW\RWSTRIP2.DGN
 USER: sdcgcky
 DATE PLOTTED: June 20, 2013
 E-SHEET NAME:
 MicroStation v8.11.7.180

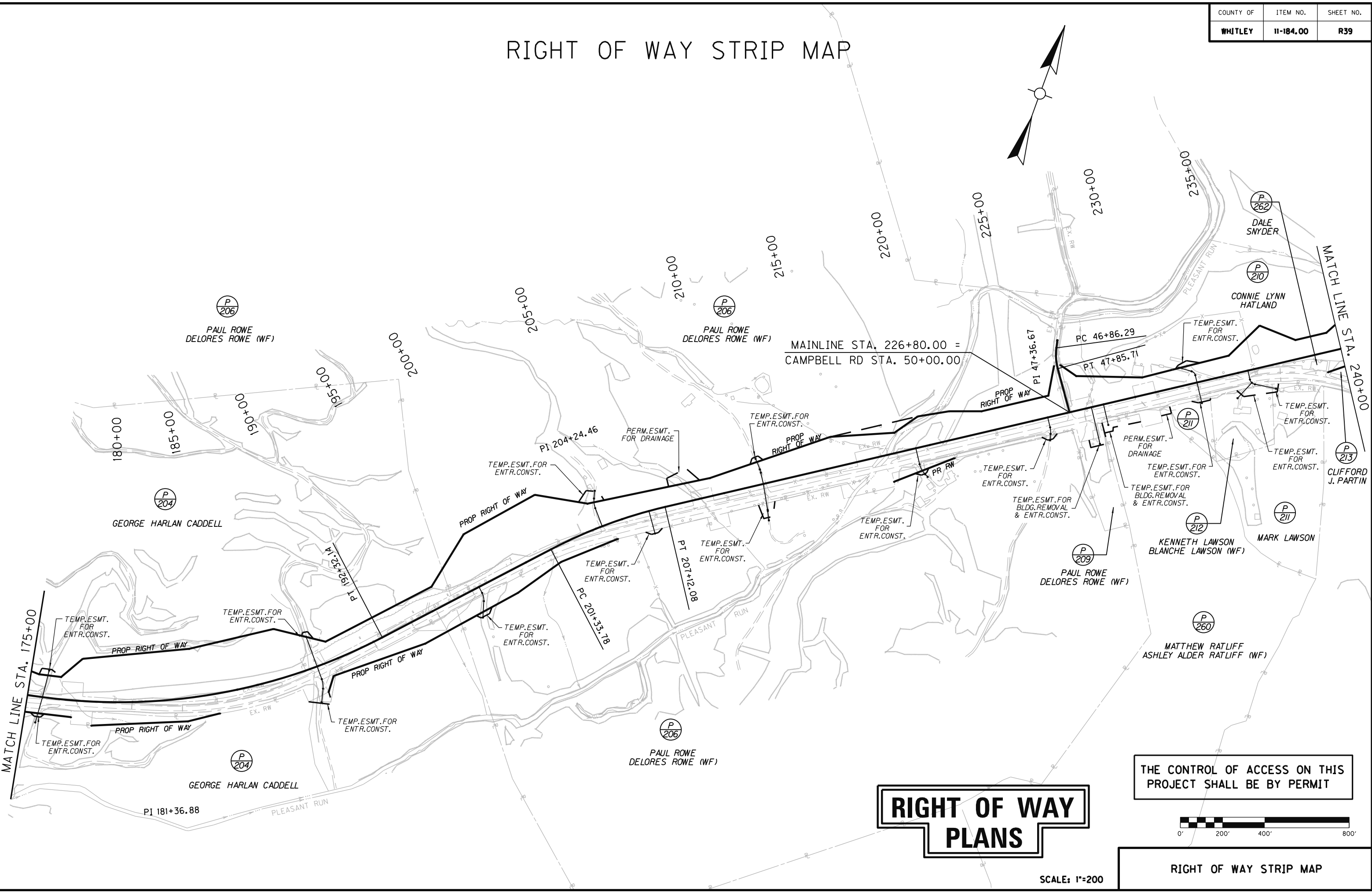

MAINLINE STA. 226+80.00 =
CAMPBELL RD STA. 50+00.00

MATCH LINE STA. 175+00

MATCH LINE STA. 240+00

**RIGHT OF WAY
PLANS**

THE CONTROL OF ACCESS ON THIS
PROJECT SHALL BE BY PERMIT

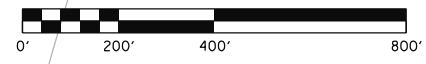

RIGHT OF WAY STRIP MAP

SCALE: 1"=200'

COUNTY OF	ITEM NO.	SHEET NO.
WHITLEY	11-184.00	R40

RIGHT OF WAY STRIP MAP

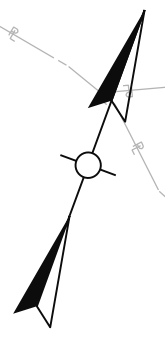
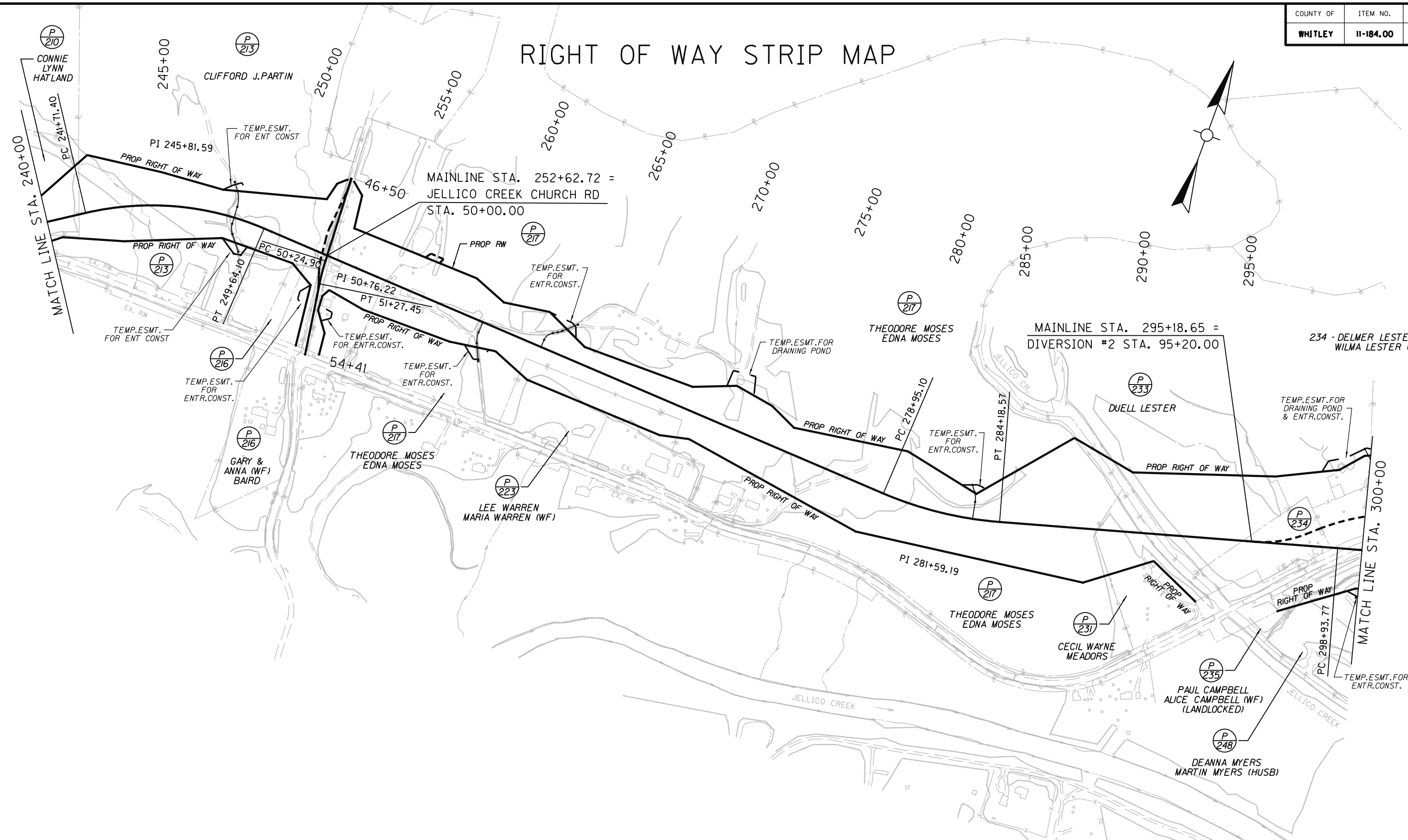

FILE NAME: G:\ENGR\HDIB5.0\PHASE 1\ACAD\PLANS\ROW\RWSTRIP3.DGN
 USER: HAYSON
 DATE PLOTTED: June 20, 2013
 E-SHEET NAME:
 MicroStation v8.11.7.180

**RIGHT OF WAY
PLANS**

THE CONTROL OF ACCESS ON THIS
PROJECT SHALL BE BY PERMIT



RIGHT OF WAY STRIP MAP

RIGHT OF WAY STRIP MAP

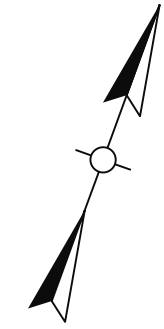

RIGHT OF WAY PLANS

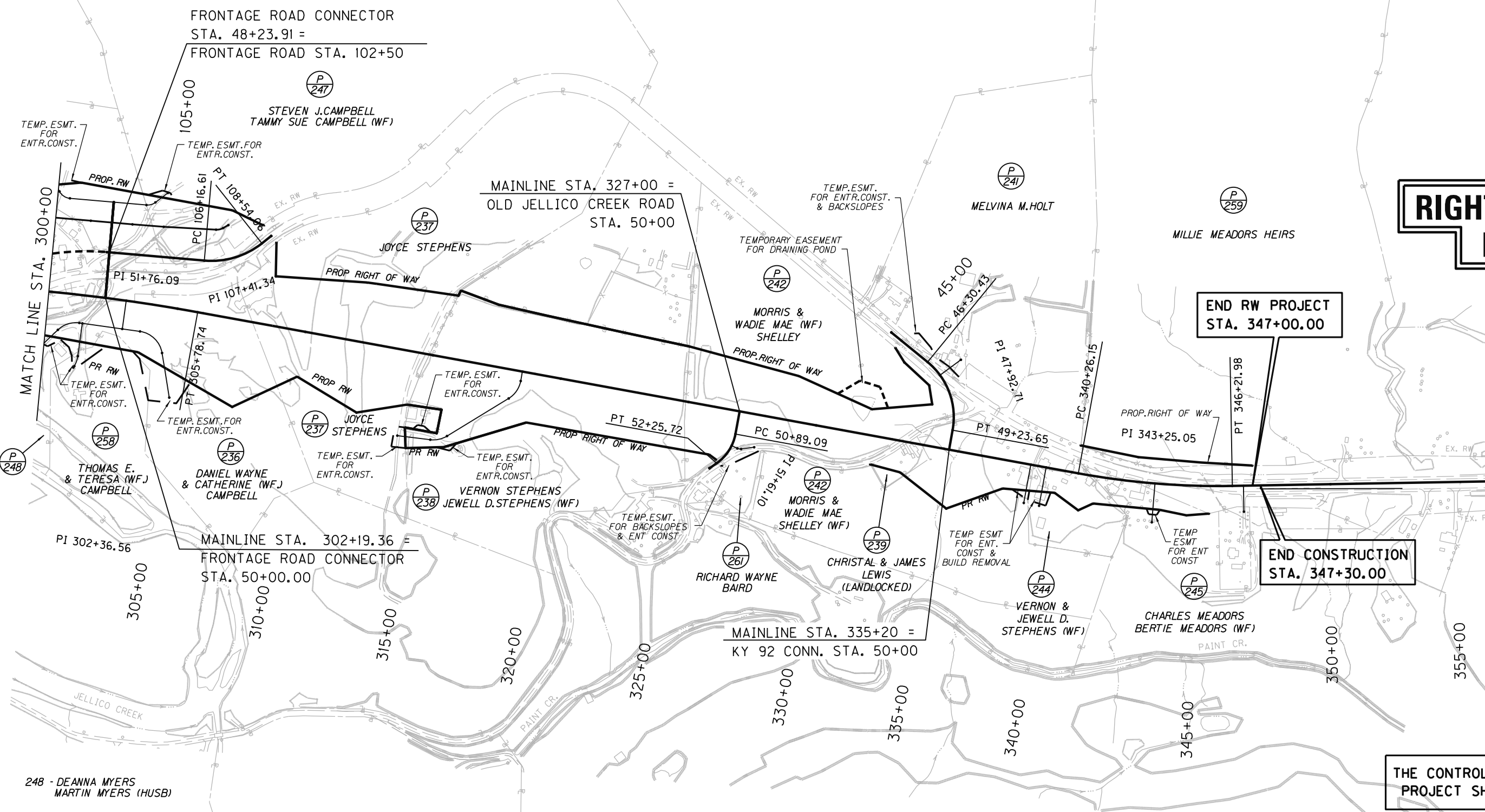

END RW PROJECT
STA. 347+00.00

END CONSTRUCTION
STA. 347+30.00

THE CONTROL OF ACCESS ON THIS PROJECT SHALL BE BY PERMIT

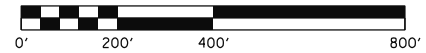

SCALE: 1"=200'

RIGHT OF WAY STRIP MAP

FILE NAME: G:\ENGR\HDIB5.0\PHASE 1\ACAD\PLANS\ROW\RWSTRIP4.DGN
 USER: HAYSON
 DATE PLOTTED: June 20, 2013
 E-SHEET NAME:
 MicroStation v8.11.7.180

248 - DEANNA MYERS
MARTIN MYERS (HUSB)

KY 92 DIV. NO. 1 CONTROL COORDINATES			
POINT	DESCRIPTION	STATE PLANE COORDINATES	
		NORTHING	EASTING
POB	133+93.03	1766613.5584	2063938.2263
PI	137+19.42	1766732.1396	2064242.3145
PT	140+45.51	1766870.2637	2064537.9610
POE	142+00.00	1766935.6550	2064677.9273

KY 1673 CONTROL COORDINATES			
POINT	DESCRIPTION	STATE PLANE COORDINATES	
		NORTHING	EASTING
POB	46+50.00	1767324.4607	2064786.4167
PC	48+55.99	1767177.8285	2064931.0984
PI	49+28.28	1767126.3724	2064981.8701
PT	49+97.37	1767056.6007	2065000.7753
POE	50+00.00	1767054.0637	2065001.4628

KY. 1673
P.I. 49+28.28
 $\Delta = 29^\circ 27' 20''$ RT
T = 72.29'
L = 141.38'
R = 275.00'
E = 9.34'
e = RC
Runoff = See Sections
Runout = See Sections
DESIGN SPEED 15 MPH

KY 92 DIVERSION #1
P.I. 137+19.42
 $\Delta = 3^\circ 44' 17''$ LT
T = 326.32'
L = 652.41'
R = 10000.00'
E = 5.32'
e = NC
Runoff = See Sections
Runout = See Sections
DESIGN SPEED 45 MPH

KY. 92
P.I. 145+34.75
 $\Delta = 36^\circ 53' 05''$ RT
T = 666.95'
L = 1287.52'
R = 2000.00'
E = 108.28'
e = 5.82%
Runoff = 149
Runout = 51
DESIGN SPEED 55 MPH

KY 92
P.I. 181+36.88
 $\Delta = 49^\circ 53' 48''$ LT
T = 1256.07'
L = 2351.32'
R = 2700.00'
E = 277.87'
e = 4.67%
Runoff = 119
Runout = 51
DESIGN SPEED 55 MPH

KY 92
P.I. 204+24.46
 $\Delta = 14^\circ 24' 22''$ Rt.
T = 290.68'
L = 578.30'
R = 2300.00'
E = 18.30'
e = 5.28%
Runoff = 135
Runout = 51
DESIGN SPEED 55 MPH

CAMPBELL RD. CONTROL COORDINATES			
POINT	DESCRIPTION	STATE PLANE COORDINATES	
		NORTHING	EASTING
POB	46+50.00	1770344.8861	2071956.2616
PC	46+86.29	1770309.4362	2071964.0437
PI	47+36.67	1770260.2350	2071974.8446
PT	47+85.71	1770219.0556	2072003.8563
POE	50+00.00	1770043.8742	2072127.2756

CAMPBELL ROAD
P.I. 47+36.67
 $\Delta = 22^\circ 47' 03''$ Lt.
T = 50.37'
L = 99.41'
R = 250.00'
E = 5.02'
e = N/A
DESIGN SPEED 15 MPH

COORDINATE CONTROL SHEET

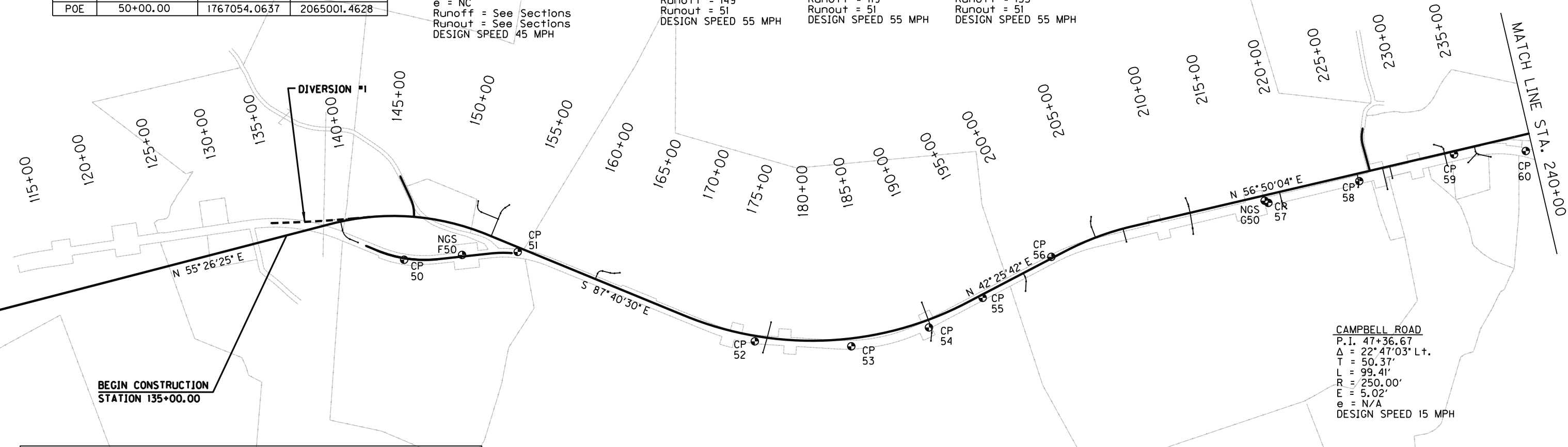
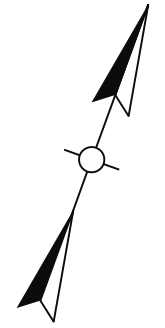

FILE NAME: G:\ENGR\HDIB5.0\PHASE I\ACAD\PLANS\ROW\COORDINATE CONTROL-1.DGN
 USER: sdcgcty
 DATE PLOTTED: June 20, 2013
 E-SHEET NAME:
 MicroStation v8.11.7.180

CONTROL POINT INFORMATION CHART (BY OTHERS)				
POINT NO.	STA. / OFFSET	NORTHING*	EASTING*	ELEVATION
CP-50	144+84.67/351.24' RT.	1766701.3306	2065045.5587	1015.49
CP-51	154+37.13/35.40' RT.	1767075.2186	2065885.7940	1017.59
CP-52	174+77.73/43.84' RT.	1767050.5370	2067931.8484	1019.72
CP-53	182+45.62/63.53' RT.	1767279.5890	2068678.2586	1011.03
CP-54	188+78.05/60.50' RT.	1767636.9298	2069215.8077	1007.24
CP-55	193+66.12/24.91' RT.	1768010.2927	2069540.9679	1005.21
CP-56	200+11.28/11.77' LT.	1768511.2492	2069949.1656	1005.83
CP-57	218+23.85/65.99' RT.	1769520.2724	2071446.6964	986.18
CP-58	225+78.70/61.99' RT.	1769936.5699	2072076.3903	1003.45
CP-59	233+73.44/25.83' RT.	1770401.6003	2072721.8805	1024.20
CP-60	239+43.95/131.11' RT.	1770625.5851	2073257.0464	1053.76
N.G.S. F-50	150+14.82/224.25' RT.	1766898.6381	2065471.8402	1014.58
N.G.S. G-50	217+98.87/42.02' RT.	1769526.6742	2071412.6747	986.104

MAINLINE CONTROL COORDINATES			
POINT	DESCRIPTION	STATE PLANE COORDINATES	
		NORTHING	EASTING
POB	135+00.00	1766562.1041	2064087.0938
PC	138+67.80	1766770.7447	2064389.9921
PI	145+34.75	1767149.0820	2064939.2510
PT	151+55.32	1767122.0256	2065605.6536
PC	168+80.81	1767052.0267	2067329.7307
PI	181+36.88	1767001.0715	2068584.7637
PT	192+32.14	1767928.2019	2069432.1913
PC	201+33.78	1768593.7236	2070040.4999
PI	204+24.46	1768808.2825	2070236.6138
PT	207+12.08	1768967.3031	2070479.9419

RIGHT OF WAY
 PLANS

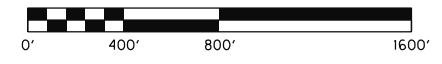

* NAD 83 STATE PLANE

SCALE: 1"=400'

COORDINATE CONTROL SHEET

DETOUR/FRONTAGE RD. CONTROL COORDINATES

POINT	DESCRIPTION	STATE PLANE COORDINATES	
		NORTHING	EASTING
PC	95+34.64	1771255.0785	2078647.0332
PI	96+49.98	1771286.0482	2078758.1330
PT	97+61.35	1771362.5543	2078844.4412
PC	98+22.40	1771403.0522	2078890.1279
PI	100+34.65	1771543.8436	2079048.9580
PT	102+39.28	1771598.8323	2079253.9592
PI	102+50.00	1771601.6105	2079264.3167
PC	106+16.61	1771696.5907	2079618.4089
PI	107+41.34	1771728.9044	2079738.8761
PT	108+54.06	1771835.0714	2079804.3366
POE	109+00.00	1771874.1767	2079828.4482

KY 92 CONN. NO. 2 CONTROL COORDINATES

POINT	DESCRIPTION	STATE PLANE COORDINATES	
		NORTHING	EASTING
POB	44+50.00	1772341.7014	2082198.8432
PC	46+30.43	1772282.1306	2082369.1509
PI	47+92.71	1772228.5500	2082522.3331
PT	49+23.65	1772068.5541	2082549.4798
POE	50+00.00	1771993.2765	2082562.2522

OLD JELICO CR. RD. CONTROL COORDINATES

POINT	DESCRIPTION	STATE PLANE COORDINATES	
		NORTHING	EASTING
POB	50+00.00	1771856.1073	2081753.8100
PC	50+89.09	1771768.2723	2081768.7131
PI	51+61.10	1771697.2748	2081780.7593
PT	52+25.72	1771638.3613	2081739.3474
POE	52+60.00	1771610.3191	2081719.6358

MAINLINE CONTROL COORDINATES

POINT	DESCRIPTION	STATE PLANE COORDINATES	
		NORTHING	EASTING
PC	241+71.40	1770859.7580	2073375.7141
PI	245+81.59	1771084.1567	2073719.0816
PT	249+64.10	1771061.4797	2074128.6445
PC	278+95.10	1770899.4414	2077055.1646
PI	281+59.19	1770884.8412	2077318.8541
PT	284+18.57	1770955.7550	2077573.2485
PC	298+93.77	1771351.8735	2078994.2726
PI	302+36.56	1771443.9203	2079324.4785
PT	305+78.74	1771501.2631	2079662.4435
PC	340+26.15	1772077.9455	2083061.2713
PI	343+25.05	1772127.9454	2083355.9587
PT	346+21.98	1772235.1064	2083634.9876
POE	356+00.00	1772585.7441	2084547.9887

KY 92
 P.I. 245+81.59
 $\Delta = 36^\circ 20' 05''$ RT
 T = 410.19'
 L = 792.70'
 R = 1250.00'
 E = 65.58'
 e = 7.56%
 Runoff = 193
 Runout = 51
 DESIGN SPEED 55 MPH

MATCH LINE STA. 240+00

KY 92
 P.I. 281+59.19
 $\Delta = 18^\circ 44' 43''$ LT
 T = 264.09'
 L = 523.47'
 R = 1600.00'
 E = 21.65'
 e = 6.71%
 Runoff = 172
 Runout = 51
 DESIGN SPEED 55 MPH

DIVERSION #2
 P.I. 96+49.89
 $\Delta = 25^\circ 58' 43''$ LT
 T = 115.34'
 L = 226.71'
 R = 500.00'
 E = 13.13'
 e = 5.60%
 Runoff = See Sections
 Runout = See Sections
 DESIGN SPEED 35 MPH

DIVERSION #2
 P.I. 100+34.65
 $\Delta = 26^\circ 32' 22''$ RT
 T = 212.25'
 L = 416.88'
 R = 900.00'
 E = 24.69'
 e = 4.40%
 Runoff = See Sections
 Runout = See Sections
 DESIGN SPEED 35 MPH

FRONTAGE ROAD
 P.I. 100+34.65
 $\Delta = 26^\circ 32' 22''$ RT
 T = 212.25'
 L = 416.88'
 R = 900.00'
 E = 24.69'
 e = 4.40%
 Runoff = See Sections
 Runout = See Sections
 DESIGN SPEED 35 MPH

FRONTAGE ROAD
 P.I. 107+41.34
 $\Delta = 43^\circ 19' 39''$ LT
 T = 124.73'
 L = 237.45'
 R = 314.00'
 E = 23.86'
 e = 8.00%
 Runoff = See Sections
 Runout = See Sections
 DESIGN SPEED 35 MPH

KY 92 CONNECTOR NO. 2
 P.I. 47+92.71
 $\Delta = 61^\circ 05' 29''$ RT
 T = 162.28'
 L = 293.22'
 R = 275.00'
 E = 44.31'
 e = 6.10%
 Runoff = See Sections
 Runout = See Sections
 DESIGN SPEED 20 MPH

KY 92
 P.I. 343+25.05
 $\Delta = 11^\circ 22' 46''$ LT
 T = 298.90'
 L = 595.83'
 R = 3000.00'
 E = 14.85'
 e = 4.29%
 Runoff = 164
 Runout = 77
 DESIGN SPEED 55 MPH

JELICO CREEK CHURCH RD.
 P.I. 50+76.22
 $\Delta = 5^\circ 52' 32''$ LT
 T = 51.32'
 L = 102.55'
 R = 1000.00'
 E = 1.32'
 e = NC
 Runoff = SEE SECTIONS
 Runout = SEE SECTIONS
 DESIGN SPEED 15 MPH

KY 92
 P.I. 302+36.56
 $\Delta = 5^\circ 56' 47''$ RT
 T = 342.80'
 L = 684.97'
 R = 6600.00'
 E = 8.90'
 e = 2.16%
 Runoff = 55
 Runout = 51
 DESIGN SPEED 55 MPH

FRONTAGE RD. CONN. CONTROL COORDINATES

POINT	DESCRIPTION	STATE PLANE COORDINATES	
		NORTHING	EASTING
POB	46+30.00	1771789.0664	2079214.6106
POE	50+00.00	1771481.5313	2079309.9380

CONTROL POINT INFORMATION CHART (BY OTHERS)

POINT NO.	STA. / OFFSET	NORTHING*	EASTING*	ELEVATION
MON-92-7	252+95.139/430.12 RT	1770613.7160	2074435.3879	1073.44
MON-92-8	263+67.30/435.75 RT	1770548.8254	2075505.6088	1102.00
MON-92-9	288+85.86/655.21 RT	1770450.0818	2078199.3177	1008.20
MON-92-10	293+40.38/332.98 RT	1770882.5268	2078550.6159	985.62
MON-92-11	328+49.54/588.31 LT	1772461.1401	2081802.8357	1177.80
MON-92-12	339+42.08/63.90 LT	1772126.8855	2082967.6956	1154.50
NGS R-193	255+29.19/468.69 RT	1770562.2660	2074666.9596	1065.785
NGS H-50	293+73.79/329.19 RT	1770895.1524	2078581.7844	974.214
NGS S-193	323+96.76/837.42 LT	1772631.0020	2081314.7547	1156.126

CONTROL POINT INFORMATION CHART (BY OTHERS)

POINT NO.	STA. / OFFSET	NORTHING*	EASTING*	ELEVATION
CP-61	247+28.88/436.07 RT.	1770620.1504	2073951.7166	1067.00
CP-62	248+58.48/66.62 RT.	1770996.2666	2074025.0078	1057.07
CP-63	252+40.96/170.45 LT.	1771216.3621	2074414.5085	1046.34
CP-64	259+79.01/58.68 LT.	1771063.9621	2075145.2493	1058.78
CP-65	264+07.61/51.06 RT.	1770930.6992	2075567.1227	1099.55
CP-66	268+85.44/174.42 RT.	1770781.1090	2076037.4108	1128.64
CP-67	274+25.35/208.86 RT.	1770716.8676	2076574.5884	1134.54
CP-68	279+58.43/55.44 RT.	1770841.7611	2077117.5754	1156.26
CP-69	282+55.01/212.28 RT.	1770710.7208	2077449.5620	1104.64
CP-70	284+55.27/144.60 RT.	1770826.3213	2077647.4331	1097.32
CP-71	287+03.33/62.77 RT.	1770971.7558	2077864.4057	999.14
CP-72	289+46.68/51.32 RT.	1771048.1312	2078095.7431	977.33
CP-73	298+07.01/101.44 LT.	1771426.2871	2078883.4590	975.93
CP-74	301+42.35/92.45 RT.	1771324.1694	2079256.3782	979.91
CP-75	304+27.58/217.26 RT.	1771260.9577	2079554.9565	1085.29
CP-76	306+93.34/227.37 RT.	1771296.2655	2079813.4579	1140.27
CP-77	313+44.52/277.36 RT.	1771355.9090	2080463.8242	1152.98
CP-78	322+52.83/100.97 LT.	1771880.8488	2081296.0511	1159.66

OLD JELICO CREEK RD.

P.I. 51+61.10
 $\Delta = 44^\circ 44' 03''$ RT
 T = 72.01'
 L = 136.63'
 R = 175.00'
 E = 14.24'
 e = 3.90%
 Runoff = See Sections
 Runout = See Sections
 DESIGN SPEED 15 MPH

JELICO CR. CHURCH RD. CTL COORDINATES

POINT	DESCRIPTION	STATE PLANE COORDINATES	
		NORTHING	EASTING
POB	46+50.00	1771394.6187	2074411.1123
POT	50+00.00	1771044.9708	2074426.8066
PC	50+24.90	1771020.0946	2074427.9232
PI	50+76.22	1770968.8285	2074430.2243
PT	51+27.45	1770918.0673	2074437.7612
POE	54+41.38	1770607.5387	2074483.8679

RIGHT OF WAY
PLANS

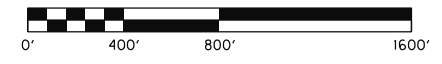

SCALE: 1"=400'

COORDINATE CONTROL SHEET

FILE NAME: G:\ENGR\HDB5\01PHASE I\ACAD\PLANS\ROW\COORDINATE CONTROL-2.DGN

USER: sdcgcurty DATE PLOTTED: June 20, 2013

E-SHEET NAME:

MicroStation v8.11.7.180

* NAD 83 STATE PLANE

RIGHT OF WAY MONUMENTS

RW MONUMENT COORDINATES			
STATION	OFFSET	STATE PLANE COORDINATES	
		NORTHING	EASTING
132+27.97	-195.24	1766568.5796	2063752.3091
135+50.00	-200.00	1766755.1746	2064014.8179
138+60.00	-175.00	1766910.4378	2064284.2958
139+65.00	-109.00	1766916.5785	2064413.9483
140+85.00	164.41	1766739.2990	2064653.2344
144+00.00	-125.00	1767129.0863	2064821.7116
144+05.00	95.00	1766923.0364	2064898.9693
144+24.95	-292.30	1767296.2636	2064793.4251
144+48.34	-305.62	1767317.3357	2064814.7812
146+16.24	-316.08	1767379.3040	2064998.8490
149+06.42	171.72	1766945.5298	2065371.3643
149+91.08	-240.05	1767361.7900	2065431.4950
150+01.85	-141.36	1767263.6362	2065447.1193
151+79.81	230.00	1766891.2214	2065620.7943
154+25.00	-165.00	1767275.9494	2065881.8082
155+00.00	115.00	1766993.1374	2065945.3876
156+25.00	-155.00	1767257.8442	2066081.2379
161+50.00	125.00	1766956.7768	2066594.4468
162+20.00	-73.00	1767151.7741	2066672.4215
163+50.00	-165.00	1767238.4246	2066806.0467
171+00.00	70.00	1766982.0869	2067551.6973
172+13.41	126.96	1766932.4863	2067672.5129
173+15.72	95.00	1766975.0710	2067775.2405
175+40.00	-105.00	1767208.3851	2067963.8711
176+50.00	-105.00	1767231.8609	2068066.9464
177+13.58	80.00	1767068.9354	2068175.0224
177+50.00	-200.00	1767348.0949	2068133.3755
178+10.13	113.85	1767064.6554	2068280.5127
182+50.00	110.00	1767240.0929	2068703.1650
183+00.00	-230.00	1767564.7097	2068590.8972
184+00.00	94.78	1767327.3372	2068832.9833
187+50.00	-235.00	1767790.0150	2068934.4052
189+03.21	131.98	1767599.2925	2069281.9268
189+50.00	70.00	1767677.9061	2069277.7778
189+75.00	-95.00	1767817.4150	2069186.2305
194+00.00	120.00	1767971.1442	2069634.0167
195+50.00	-105.00	1768233.6626	2069569.1394
198+00.00	-255.00	1768519.3932	2069627.0880
199+00.00	110.00	1768346.9517	2069963.9692
201+50.00	75.00	1768554.6677	2070106.4858
201+80.00	-265.00	1768810.2049	2069880.0532
203+75.00	-125.00	1768856.4494	2070129.3432
204+50.00	81.50	1768749.0431	2070321.2451
209+50.00	-85.00	1769168.6132	2070632.6040
215+50.00	-145.00	1769547.0749	2071102.0364
217+95.81	130.71	1769450.7530	2071458.6369
218+50.00	-95.00	1769669.3382	2071380.5174
219+75.00	-145.00	1769779.5754	2071457.8011
221+00.00	87.02	1769653.7317	2071689.3691
221+25.00	-135.00	1769853.2635	2071588.8357
222+75.00	-100.00	1769906.0242	2071733.5468
226+00.00	-100.00	1770083.8188	2072005.6021
226+58.16	-230.58	1770224.9490	2071982.8546
226+88.19	-228.34	1770239.4955	2072009.2133
227+50.00	-160.00	1770216.1034	2072098.3425
230+51.99	-82.66	1770316.5737	2072393.4473
234+75.00	-90.00	1770554.1254	2072743.5294
236+50.00	-195.00	1770737.7557	2072832.5794
238+00.00	-90.00	1770731.9199	2073015.5847
239+15.75	93.97	1770641.2410	2073213.1275
239+50.00	-90.00	1770813.9790	2073141.1487
240+50.00	80.00	1770726.3791	2073317.8583
242+25.00	-245.00	1771098.7562	2073296.0851
243+25.00	150.00	1770801.0112	2073575.1766
245+00.00	-145.00	1771139.3343	2073626.0645
247+50.00	-105.00	1771159.2905	2073902.7575

RW MONUMENT COORDINATES			
STATION	OFFSET	STATE PLANE COORDINATES	
		NORTHING	EASTING
248+00.00	100.00	1770960.0747	2073972.2626
251+37.09	90.09	1770961.9600	2074296.3930
251+65.00	-225.00	1771275.0288	2074341.6785
251+80.00	-305.00	1771354.0772	2074361.0783
252+14.42	-338.95	1771386.0700	2074397.3271
252+44.29	-341.77	1771387.2415	2074427.3046
252+47.23	146.83	1770899.2205	2074403.2293
252+91.43	413.80	1770630.2129	2074432.5973
253+00.00	-300.00	1771342.4508	2074480.6183
253+13.00	170.00	1770872.4509	2074467.6148
253+20.00	235.00	1770807.1633	2074471.0106
253+25.00	-155.00	1771196.2904	2074497.5639
253+30.00	135.00	1770906.4575	2074486.5238
253+85.00	315.00	1770723.6922	2074531.4885
254+00.00	410.29	1770627.7194	2074541.1976
255+00.00	155.00	1770877.0898	2074655.1581
259+00.00	135.00	1770874.9455	2075055.6520
259+00.00	-165.00	1771174.4867	2075072.2373
260+50.00	-115.00	1771116.2705	2075219.2437
261+00.00	95.00	1770903.8274	2075257.5576
262+50.00	-155.00	1771145.1525	2075421.1492
262+75.00	155.00	1770834.2445	2075428.9729
264+50.00	-75.00	1771054.2180	2075616.4206
269+00.00	150.00	1770804.6842	2076053.2934
269+50.00	-100.00	1771051.5376	2076117.0380
270+25.00	115.00	1770832.7201	2076180.0372
271+25.00	-180.00	1771121.7405	2076296.1931
273+00.00	-160.00	1771092.0964	2076469.8198
274+25.00	-110.00	1771035.2623	2076591.8644
278+50.00	200.00	1770702.2406	2076999.0764
279+25.00	-210.00	1771107.9266	2077092.7218
283+00.00	-110.00	1771036.0328	2077436.3500
287+15.00	-390.00	1771411.0297	2077754.0725
288+00.00	235.00	1770831.8071	2078003.7747
289+80.00	-260.00	1771356.9613	2078044.2476
291+00.00	118.00	1771025.0657	2078261.3404
292+93.65	278.89	1770922.0792	2078491.0847
296+00.00	-290.00	1771552.3409	2078633.4223
296+53.99	293.41	1771004.8528	2078842.0883
298+75.00	-340.00	1771674.3471	2078884.8969
299+75.00	-410.00	1771769.4711	2078967.4294
299+90.00	168.00	1771214.5660	2079129.9016
300+80.00	-430.00	1771816.6433	2079070.6153
303+75.00	190.00	1771277.8334	2079499.6785
306+40.00	-410.00	1771915.7329	2079654.2518
307+65.00	-374.72	1771901.8584	2079783.3924
307+75.00	335.00	1771203.8133	2079911.9733
308+28.93	-318.69	1771857.3151	2079855.7952
308+50.00	-190.00	1771733.9617	2079898.0944
310+00.00	175.00	1771399.1968	2080107.0381
312+00.00	-230.00	1771831.9462	2080236.4715
312+50.00	270.00	1771347.3555	2080369.4071
314+35.00	205.00	1771442.3864	2080540.9271
314+43.38	293.04	1771356.9890	2080563.9120
314+60.29	370.38	1771283.5673	2080593.5279
315+55.08	-243.39	1771904.5432	2080584.3132
315+61.25	-264.26	1771926.1560	2080586.8960
315+68.00	293.00	1771377.8747	2080686.7737
315+70.00	200.00	1771469.8988	2080673.1885
316+05.00	340.00	1771337.7263	2080731.1145
317+14.28	-237.08	1771924.9550	2080742.3230
319+00.00	190.00	1771534.9604	2080996.8658
324+65.05	-211.16	1772024.9860	2081486.8500
326+15.00	185.00	1771659.4953	2081700.9546
326+43.48	199.03	1771650.4223	2081731.3792

RW MONUMENT COORDINATES			
STATION	OFFSET	STATE PLANE COORDINATES	
		NORTHING	EASTING
329+00.00	-175.00	1772062.0975	2081921.7179
332+00.00	-100.00	1772038.3384	2082230.0367
332+31.63	110.43	1771836.1615	2082296.4194
332+46.39	-348.68	1772291.2728	2082234.1708
332+90.00	-300.00	1772250.5754	2082285.3125
333+50.00	120.00	1771846.5303	2082414.7248
334+00.00	-230.00	1772199.9626	2082405.4722
334+25.00	-160.00	1772135.1310	2082441.8295
335+50.00	225.00	1771776.4659	2082629.4711
337+50.00	110.00	1771923.3015	2082807.4157
339+50.00	90.00	1771976.4757	2083001.2520
340+16.44	-107.45	1772182.2614	2083033.7290
340+50.00	140.00	1771944.1923	2083109.2875
341+00.00	105.00	1771988.1378	2083154.0310
342+50.00	-95.00	1772215.8031	2083257.5387
343+50.00	100.00	1772053.0168	2083404.2725
344+50.00	115.00	1772068.5419	2083507.7733
345+33.00	106.37	1772104.0588	2083586.6335
347+00.00	-77.14	1772335.0913	2083680.1663

FILE NAME: G:\ENGR\HDIB5.0\PHASE I\ACAD\PLANS\ROW\RWMON.DGN

USER: sdcgcurry
DATE PLOTTED: June 20, 2013

E-SHEET NAME:

MicroStation v8.11.7.180

RIGHT OF WAY PLANS

• NO RW MONUMENT

RIGHT OF WAY MONUMENT SHEET